

Panasonic®

KW8M Eco-Power Meter User's Manual

 This manual was created using Adobe Acrobat.
Adobe, the Adobe logo, and Acrobat are trademarks
of Adobe Systems Incorporated.

KW8M Eco-Power Meter User's Manual
ARCT1F440E-1 '07.10

Cautions for Your Safety

Read the manual carefully before installing, running and maintenance for proper operation. Before using, master the knowledge of the equipment, safety information and all of other notes.

This manual uses two safety flags to indicate different levels of danger.



WARNING

A handling error could cause serious physical injury to an operator and in the worst case could even be fatal.

- Always take precautions to ensure the overall safety of your system, so that the whole system remains safe in the event of failure of this product or other external factor.
- Do not use this product in areas with inflammable gas. It could lead to an explosion.
- Exposing this product to excessive heat or open flames could cause damage to the lithium battery or other electronic parts.



CAUTION

A handling error could cause serious physical injury to an operator or damage to the equipment.

- To prevent abnormal exothermic heat or smoke generation, use this product at the values less than the maximum of the characteristics and performance that are assured in these specifications.
- Do not dismantle or remodel the product. It could lead to abnormal exothermic heat or smoke generation.
- Do not touch the terminal while turning on electricity. It could lead to an electric shock.
- Use the external devices to function the emergency stop and interlock circuit.
- Connect the wires or connectors securely. The loose connection might cause abnormal exothermic heat or smoke generation.
- Do not allow foreign matters such as liquid, flammable materials, metals to go into the inside of the product. It might cause exothermic heat or smoke generation.
- Do not undertake construction (such as connection and disconnection) while the power supply is on.

Copyright and trademark

- Matsushita Electric Works, Ltd. owns the copyright of this manual.
- We stiffly refuse the reproduction of without permission from this manual.
- Modbus Protocol is a communication protocol that the Modicon Inc. developed for PLC.
- Other company names and the product names are the trademarks or registered trademarks of each company.

Introduction

Thank you very much indeed for purchasing
“KW8M Eco-POWER METER”.

In this manual, we explain the usage of “KW8M
Eco-POWER METER” in detail.

Please use it correctly after understanding the content
enough.



Table of Contents

Cautions before using	i
Chapter 1 Unit's Features and Structure.....	1
1-1 Features.....	1
1-2 Unit's Name and Part Numbers.....	1
1-2-1 Main unit.....	1
1-2-2 Dedicated Current Transformer (CT).....	1
1-2-3 Options.....	1
1-3 Measurement items	2
Chapter 2 Parts Name and Working	3
2-1 Parts Names.....	3
2-2 Select Keys' Functions	3
Chapter 3 Display of each Value.....	4
3-1 Outline for the Working of Monitor Display.....	4
3-2 Integrated Electric power	5
3-3 Instantaneous Electric power	6
3-4 Current.....	6
3-5 Voltage.....	7
3-6 Electricity Charge.....	8
3-7 Power factor.....	8
3-8 Frequency.....	8
3-9 Hour meter.....	9
3-10 Counter	10
Chapter 4 Various Functions.....	11
4-1 LOCK mode.....	11
4-2 Display while communication	11
4-3 Display when pulse output.....	11
Chapter 5 Settings	12
5-1 Operation procedure.....	12
5-2 Setting Mode Explanation.....	13
5-2-1 MODE1	13
5-2-2 MODE2	19
5-2-3 MODE3	20
5-2-4 MODE4	23
Chapter 6 Wiring.....	24
6-1 Main unit terminal arrangement.....	24
6-2 Wiring Diagrams	25
6-3 For input connection	29
6-4 For Output connection	29
6-5 RS485 Communication.....	30
6-6 Low Voltage Directive	31
Chapter 7 MEWTOCOL Communications	32
7-1 Communication Procedures	32
7-2 Communication timing	32
7-3 MEWTOCOL Communication	33
7-3-1 Overview of MEWTOCOL-COM (RS485).....	33
7-3-2 Data Register List	34
7-3-3 Error Codes.....	36
7-3-4 Command.....	36
7-4 MODBUS (RTU) Communication	38
7-4-1 Overview of MODBUS (RTU)	38
7-4-2 Data Register List	41

Chapter 8 Specifications	43
8-1 Main unit	43
8-2 Input Specifications	44
8-2-1 Electric power input.....	44
8-2-2 Pulse input	45
8-3 Pulse output (Transistor output) Specifications.....	45
8-4 Communication Specifications	46
8-5 Dedicated Current Transformer Specifications	46
8-6 Self-diagnostic function	47
8-7 Power Failure Memory	47
Chapter 9 Mounting	48
9-1 Dimensions	48
9-1-1 Main unit.....	48
9-1-2 Dedicated CT	49
9-2 Panel cutout.....	51
9-3 Panel mounting.....	51



Cautions before using

■ Installation environment

◇Do not use the Unit in the following environments.

- Where the unit will be exposed to direct sunlight and where the ambient temperature is outside the range of -10 to 50 °C.
- Where the ambient humidity is outside the range of 30 to 85 % RH (at 20°C non-condensing) and where condensation might occur by sudden temperature changes
- Where inflammable or corrosive gas might be produced
- Where the unit will be exposed to excessive airborne dust or metal particles
- Where the unit will be exposed to water, oil or chemicals
- Where organic solvents such as benzene, paint thinner, alcohol, or strong alkaline solutions such as ammonia or caustic soda might adhere to the product
- Where direct vibration or shock might be transmitted to the product, and where water might wet the product

◇Please use the Unit according to the specifications described in this manual. Otherwise, it may malfunction or cause fire and an electric shock.

- Connect to the power supply in compliance with the rating.
- Refer to the wiring diagram to ensure proper wiring for the power supply, input and output.
- Do not perform wiring or installation with a live line. It may also lead to circuit burnout or fire by way of the secondary CT side opening.
- Do not add voltage and current to an output terminal from outside.

■ Installation

- Installation and wiring must be performed by expert personnel for electrical work or electric piping.
- The power supply terminal and voltage input terminal of the main unit is common. Therefore if additional noise affects the power supply line, incorrect measurements may result.
- Eco-POWER METER is designed to be used in a control panel.
- As to measurement
If there is some distortion by harmonic or waveform, it may not measure correctly.
Please check with the actual system before adopts it.

■ Static electricity

- Discharge static electricity touching the grounded metal etc. when you touch the unit.
- Excessive static electricity might be generated especially in a dry place.

■ Cleaning

- Wipe dirt of the main unit with soft cloth etc. When thinner is used, the unit might deform or be discolored.

■ Power supply

- Connect a breaker to the voltage input part for safety reasons and to protect the device.
The breaker that connects to the voltage input part must arrange at the position easily reached, and display shows it is the breaker of the equipment.
- Do not turn on the power supply or input until all wiring is completed.

■ Before power on

Please note the following points when turning on power at the first time.

- Confirm there are neither wiring rubbish nor especially an electrical conduction when installed.
- Confirm neither the power supply wiring, the I/O wiring nor the power-supply voltage are wrong.
- Tighten the installation screw and the terminal screw surely.
- Use an electric wire applicable to the rated current.

Chapter 1 Unit's Features and Structure

1-1 Features

■ With KW8M Eco-POWER METER, electrical power (voltage, current, etc.), power factor, frequency, etc are measured using AC voltage and AC current input via one of the following systems: single-phase two-wire system, single-phase three-wire system, three-phase three-wire system or three-phase four-wire system.

This also works as an hour meter, that is measured power-on or power-off time, and as a counter that is for pulse output equipment like flowmeter.

■ **Eco-POWER METER is designed chiefly to manage saving energy. It is neither intended nor can it be legally used for billing.**

1-2 Unit's Name and Part Numbers

1-2-1 Main unit

Part No	Phase and Wire system	Power supply	Measured voltage input	Measured current input	Current transformer	Terminal type
AKW8111	<ul style="list-style-type: none"> • Single-phase two-wire • Single-phase three-wire • Three-phase three-wire • Three-phase four-wire (common) 	100-240V AC	<ul style="list-style-type: none"> • 400VAC • 100/200VAC 	<ul style="list-style-type: none"> • 50A • 100A • 250A • 400A 	Dedicated CT type (5A,50A(common)/100A/250A/400A)	Screw Terminal (M3 + screw)

1-2-2 Dedicated Current Transformer (CT)

Rated primary current	Part No
5A	AKW4801
50A	
100A	AKW4802
250A	AKW4803
400A	AKW4804

1-2-3 Options

Product name	Part No
Terminal cover	AKT8801

1-3 Measurement items

Item		Unit	Data range
Integrated electric power	Active	kWh	0.00~9999999.9
	Reactive	kvarh	0.00~9999999.9
	Apparent	kVAh	0.00~9999999.9
Instantaneous electric power	Active	kW	0.00~999999.99
	Reactive	kvar	0.00~999999.99
	Apparent	kVA	0.00~999999.99
Current	CT1	A	0.0~6000
	CT2	A	0.0~6000
	CT3	A	0.0~6000
Voltage	Between P1-P0	V	0.0~9999
	Between P2-P0	V	0.0~9999
	Between P3-P0	V	0.0~9999
Electricity charge ※			0.00~99999999
Power Factor			0.00 ~ 1.00
Frequency	Hz		47.5 ~ 63.0
Hour meter	ON-time	hour	0.0~99999.9
	OFF-time		
Pulse counter			0 ~ 99999999

※Eco-POWER METER is designed chiefly to manage saving energy.
It is neither intended nor can it be legally used for billing.

Chapter 2 Parts Name and Working

2-1 Parts Names

- ① Display indicator · Lighting or Blinking according to the display
- ② LOCK indicator · Lighting while in lock mode
- ③ T/R indicator · Blinking while communication
- ④ OUT indicator · Lighting when pulse output
- ⑤ Display each value · Display each measured value
 · Display each setting value
- ⑥ MODE Key
- ⑦ SET Key
- ⑧ ITEM / Δ Key
- ⑨ SHIFT / ∇ Key
- ⑩ Left / Right (\triangleleft / \triangleright) keys
- ⑪ OPTION キー
- ⑫ START/STOP キー

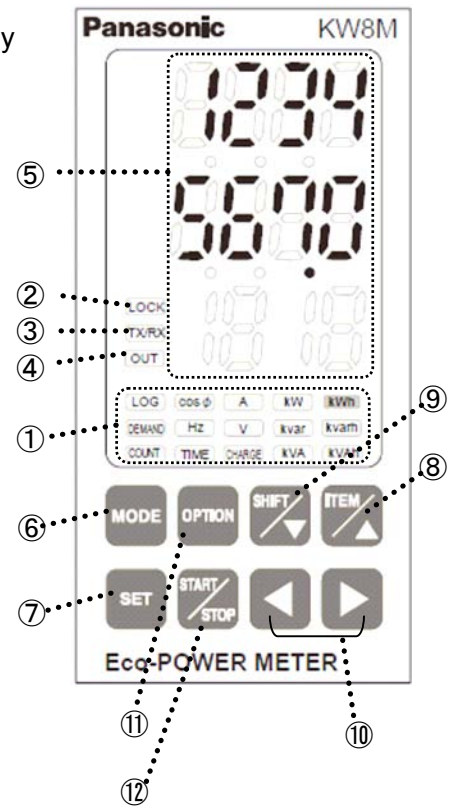

2-2 Select Keys' Functions

Key	Functions
⑥ <MODE>	· Use to select mode
⑦ <SET>	· Use to set each value entered
⑧ < ITEM / Δ >	· To select measured display · To shift each mode · To change each setting value
⑨ < SHIFT / ∇ >	· To select measured display · To shift each mode · To change each setting value
⑩ < Left / Right (\triangleleft / \triangleright) >	· To change each setting value
⑦ + ⑥ <SET> + <MODE>	· Reset the measured value
⑦ <SET> (continuous press 3-sec)	· All keys locked · Release lock mode while in lock mode
⑪ <OPTION>	· Not use these keys
⑫ <START/STOP>	

Chapter 3 Display of each Value

3-1 Outline for the Working of Monitor Display

Turn of the power supply and it displays measured value. (It displays integrated active power at initial.)

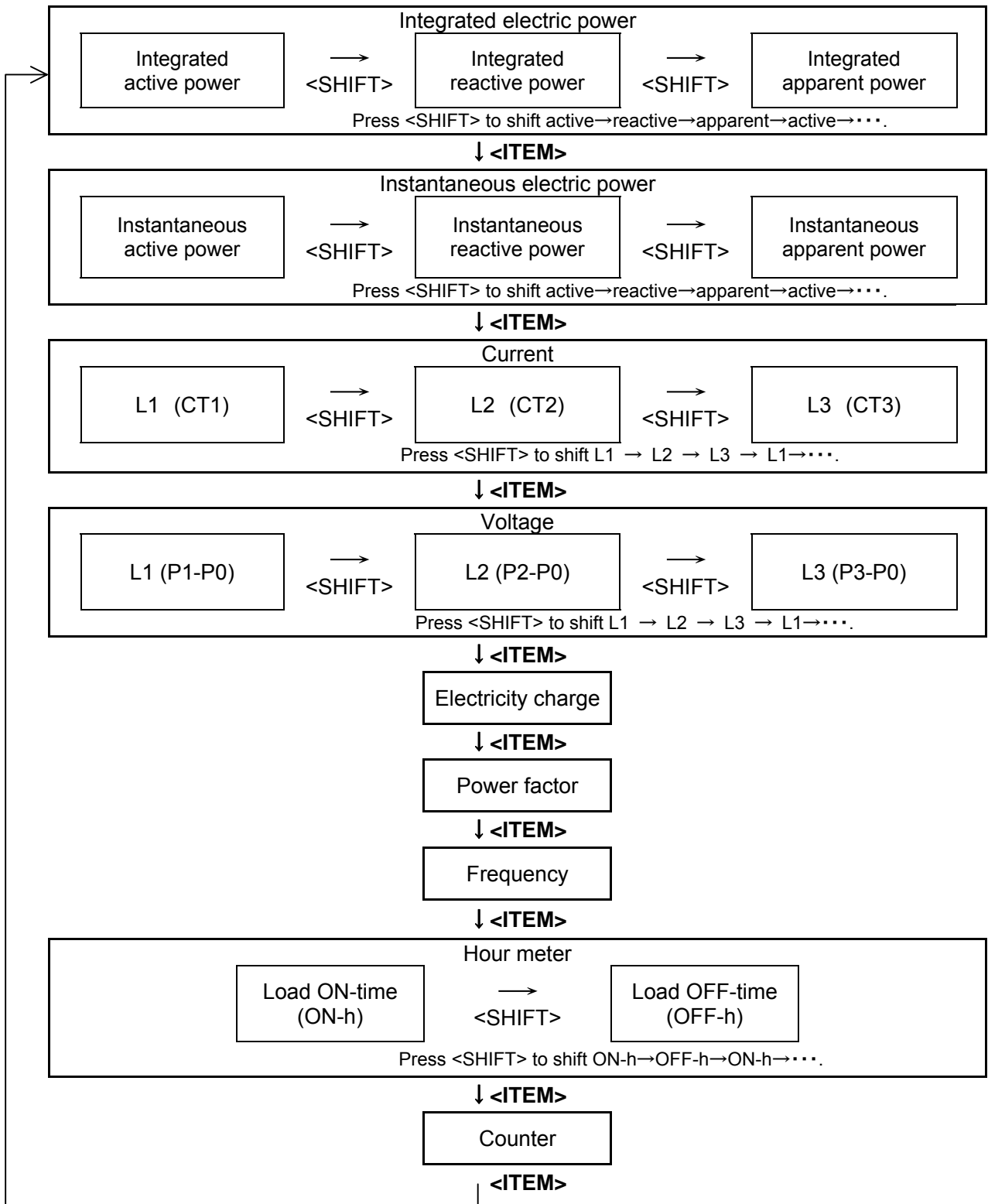

3-2 Integrated Electric power

- Power on to display the integrated electric power.
- Press <Shift>key to shift active power, reactive power, apparent power.

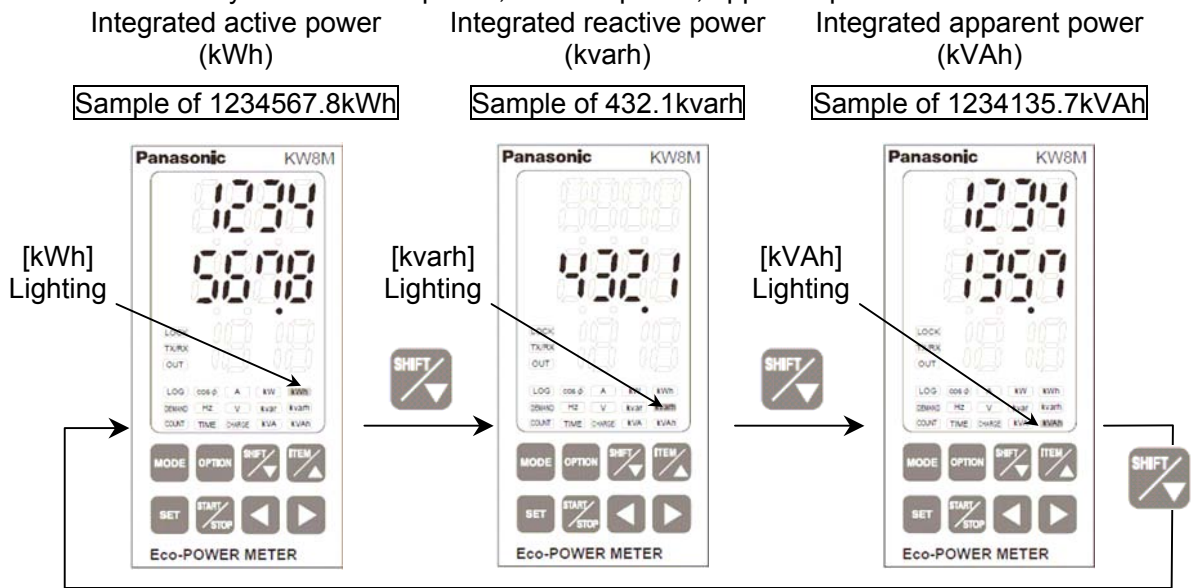

- Integrated electric power is measured and displayed from 0.00 to 9999999.9 (kWh/kvarh/kVAh).
- The decimal point is changed automatically.

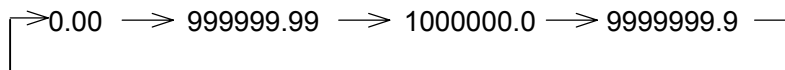

(After reaching the full-scale (9999999.9), the value reverts to 0.00 but continues to measure.)

How to reset the integrated electric power (active/reactive/apparent)

- Hold down <SET>key and press <MODE>key makes integrated electric power clear.
(Active power, reactive power, apparent power are reset by each.)

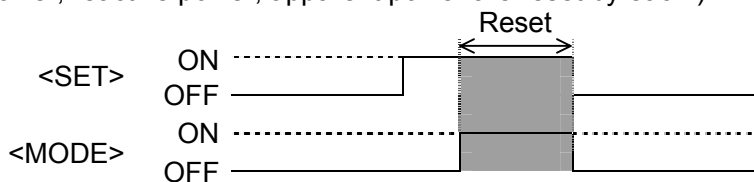

3-3 Instantaneous Electric power

- Press <ITEM> key to display the Instantaneous electric power.
- Press <Shift> key to shift active power, reactive power, apparent power.

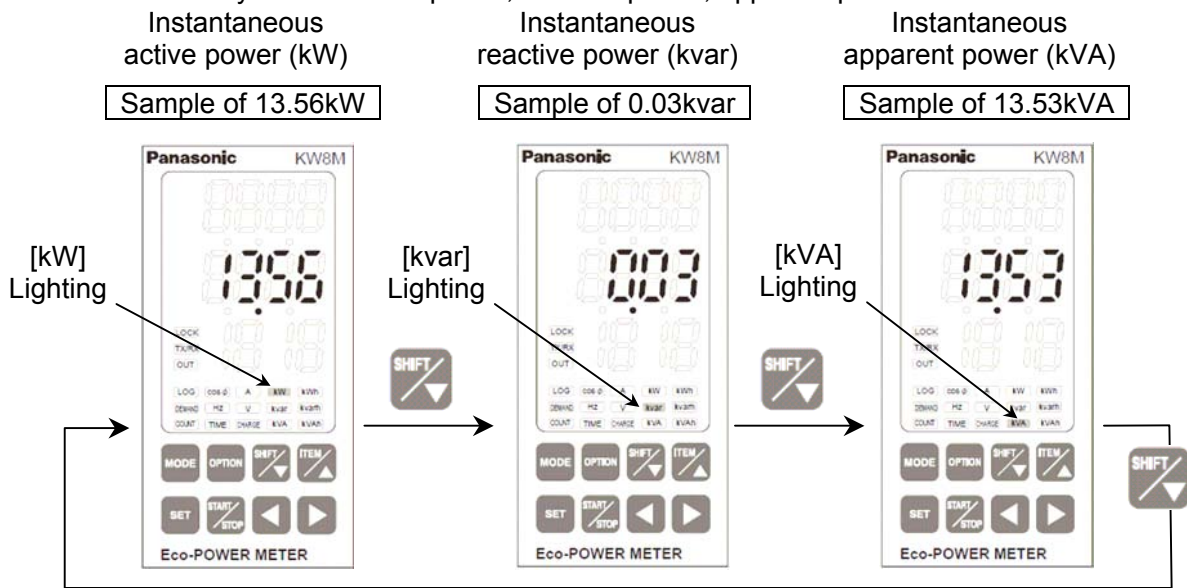

3-4 Current

- Press <ITEM>key to display the current value of the load.
- Press <Shift>key to change L1(CT1)-phase, L2(CT2)-phase, L3(CT3)-phase current.

※Before start measuring, select phase and wire system according to the measured load.

When Single-phase 3-wire or Three-phase 3-wire is selected, it doesn't measure Single-phase 2-wire system correctly. When Three-phase 4-wire system is selected, it doesn't measure Single-phase 2-wire, Single-phase 3-wire, Three-phase 3-wire system correctly.

Select phase and wire system according to the measured system. (Refer to the explanation of setting mode.)

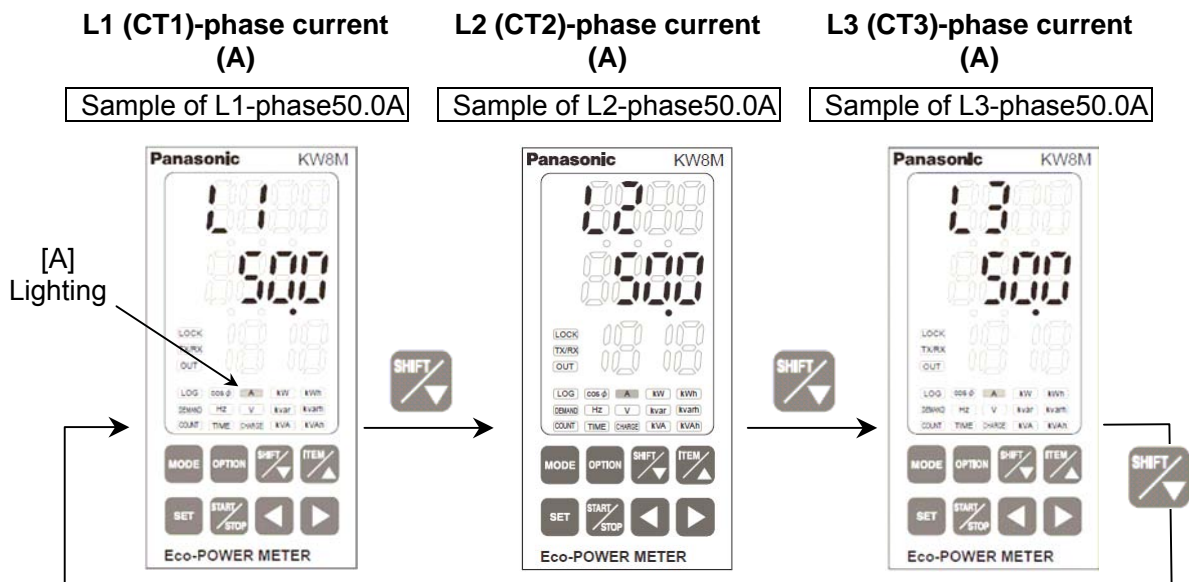

- When input current exceeds 150%F.S. at each range, 「」 will be displayed.

- Current measurement parts
Eco-POWER METER measures the current as below.

System \ Display	L1 (CT1)	L2 (CT2)	L3 (CT3)
Single-phase two-wire	L1-phase current	-	-
Single-phase three-wire	L1(R)-phase current	L2 (S)-phase current	-
Three-phase three-wire	L1(R)-phase current	L2 (T)-phase current	-
Three-phase four-wire	L1(R)-phase current	L2 (S)-phase current	L3 (T)-phase current

3-5 Voltage

- Press <ITEM>key to display the voltage value of the load.
- Press <SHIFT>key to change voltage between P1 and P0, P2 and P0, P3 and P0.

※Before start measuring, select phase and wire system according to the measured load.

When Single-phase 3-wire or Three-phase 3-wire is selected, it doesn't measure Single-phase 2-wire system correctly. When Three-phase 4-wire system is selected, it doesn't measure Single-phase 2-wire, Single-phase 3-wire, Three-phase 3-wire system correctly. Select phase and wire system according to the measured system. (Refer to the explanation of setting mode.)

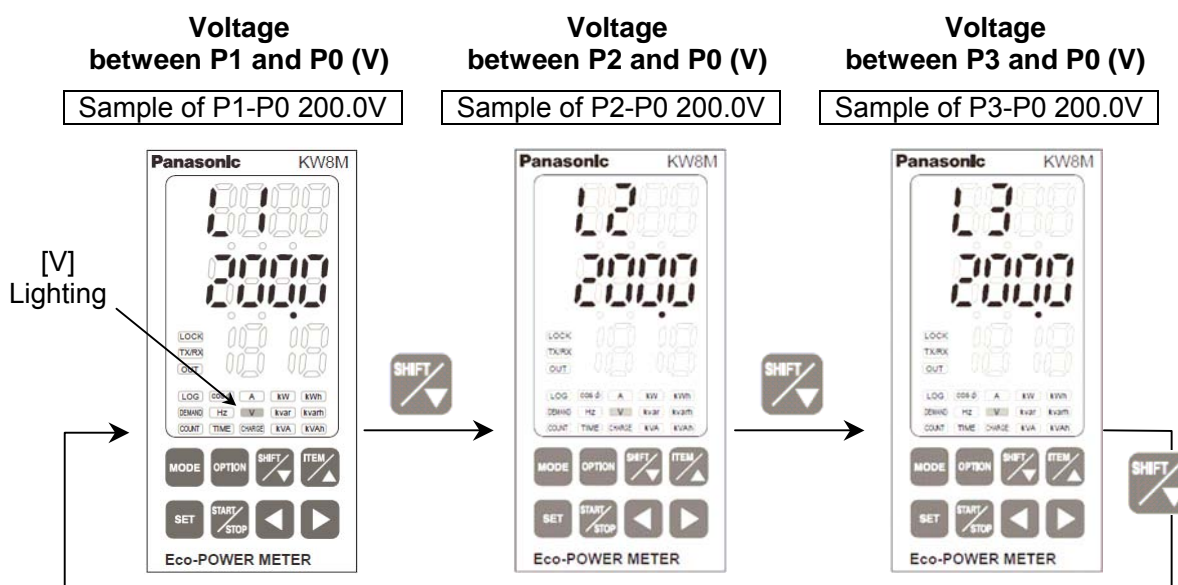

- When input voltage is under 10.0V at 200V range, and when input voltage is under 20.0V at 400V range, it displays "0.0" and doesn't measure.
- When input voltage exceeds 150%F.S. at each range, 「」 will be displayed.
- Voltage measurement parts

Eco-POWER METER measures the voltage as below.

System \ Display	L1V	L2V	L3V
Single-phase two-wire	Voltage between P1 and P0	---	---
Single-phase three-wire	Voltage between P1 and P0	Voltage between P2 and P0	---
Three-phase three-wire	Voltage between P1 and P0	Voltage between P2 and P0	---
Three-phase four-wire	Voltage between P1 and P0	Voltage between P2 and P0	Voltage between P3 and P0

3-6 Electricity Charge

It displays the standard electricity charge for the integrated electrical power.

- Press <ITEM>key to display the electricity charge.

Electricity Charge

Sample of 1234567.8

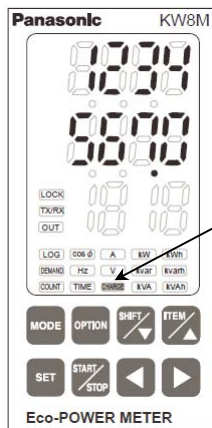

[CHARGE]
Lighting

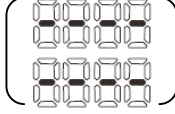
※When the value exceeds '99999999',  will be displayed.

3-7 Power factor

- Press <ITEM>key to display the loads' power factor.

※Before start measuring, select phase and wire system according to the measured load.

When selected system does not meet it, it can not measure correctly. (Refer to the explanation of setting mode.)

Power factor

Sample of 1.00

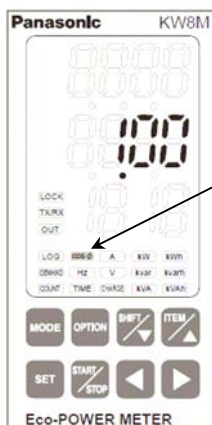

[cos φ]
Lighting

3-8 Frequency

- Press <ITEM>key to display the loads' power factor.

Frequency

Sample of 50.0



[Hz]
Lighting

3-9 Hour meter

- Press <ITEM> key to display the load ON-time or load OFF-time measured by CT1.
 - Press <SHIFT> key to change the load ON-time to load OFF-time.
- * "ON-h" and OFF-h" display disappears after a few seconds by pressing <ITEM>key or <SHIFT>key.

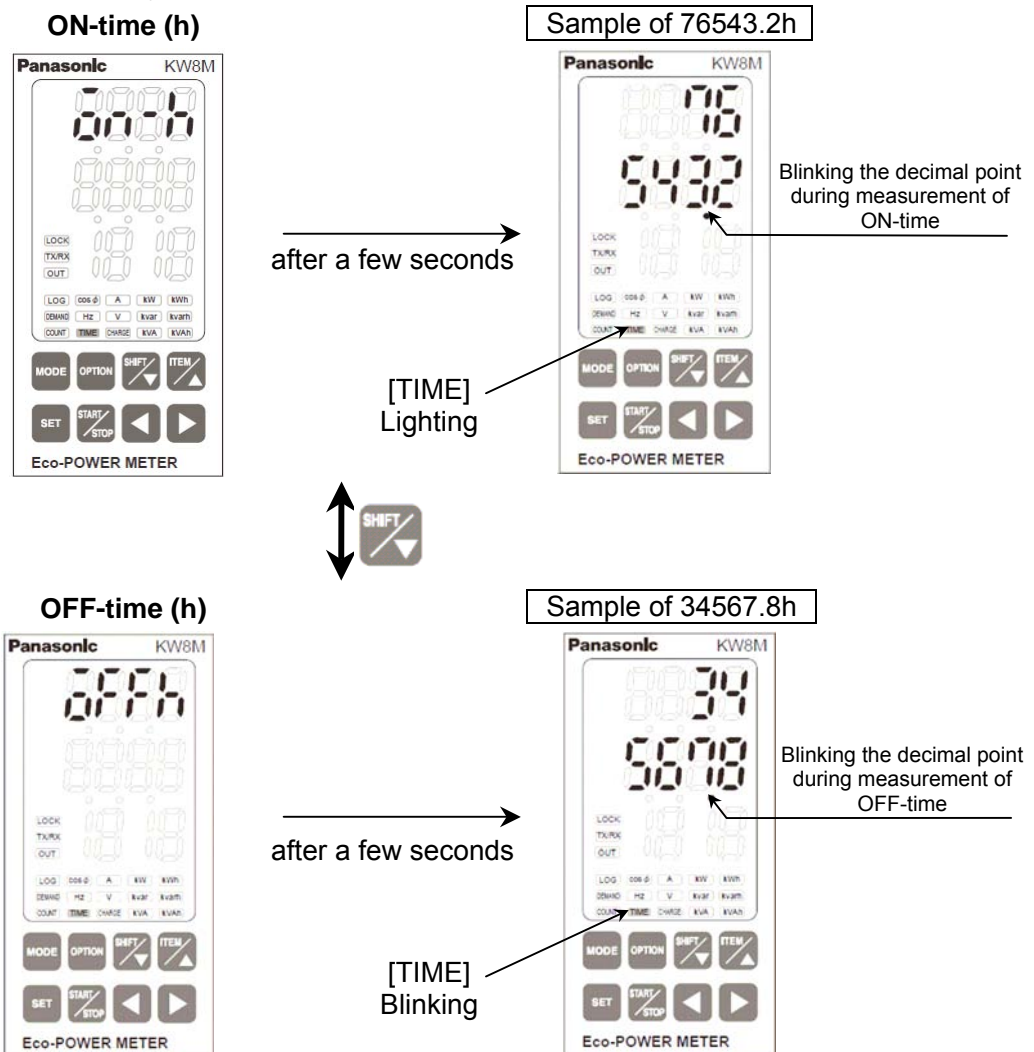

* When load current is under the setting current for time measurement (HM-A), it measures as OFF-time. When load current is exceeded to the setting current for time measurement (HM-A), it measures as ON-time. Current for time measurement (HM-A) is set to under cutoff current (CUTA), all current is measured as OFF-time.

* Current flow of CT1

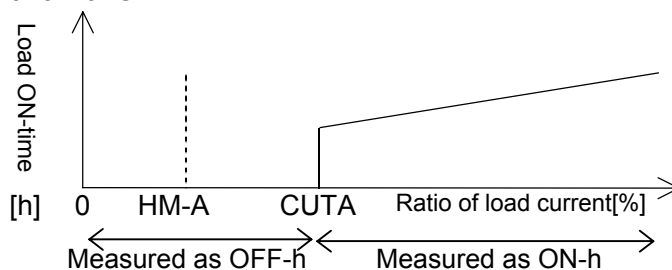

* After reaching the full scale (99999.9h), the value reverts to 0.0h but continues to measure.

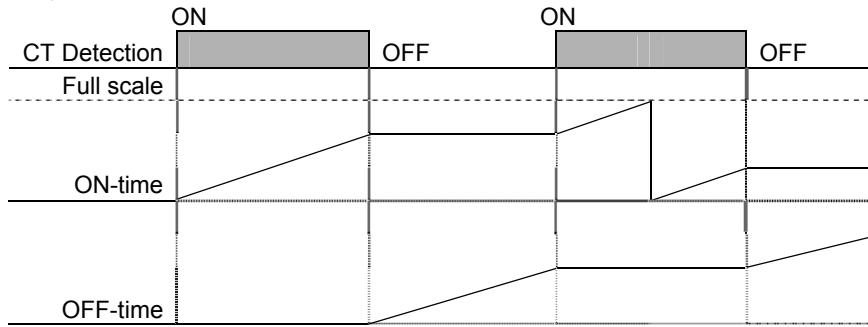

How to Reset ON/OFF-time

• Hold down <SET> key and press <MODE> key makes ON-time or OFF-time clear. (ON-time and OFF-time are reset by each.)

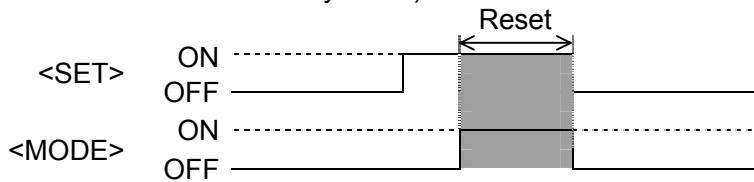

3-10 Counter

It displays present count value (pulse input value).

• Press <ITEM> key to display count value (pulse input value).

Count value (COUNT)

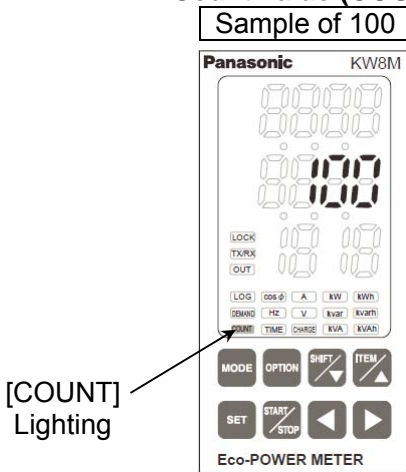

* After reaching the full scale (99999999), the value reverts to 0 but continues to measure.

How to enter preset value

• It is entered and set at preset setting mode of MODE1. (Refer to the explanation of setting mode.)

How to Reset Count value

• Hold down <SET> key and press <MODE> key makes count value clear.

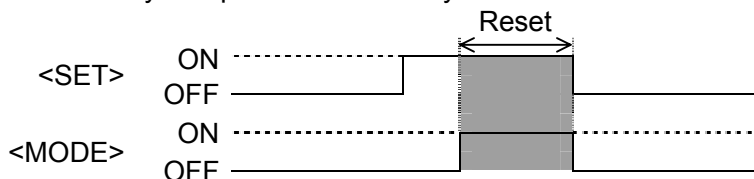

Chapter 4 Various Functions

4-1 LOCK mode

It is the mode makes all keys unable. Use when you want to fix one of the measurement displays (For all displays). In this mode, you can not input by any keys.

When you press <SET>key continuously for about 3sec., the "LOCK" is displayed and the indicator lights. After about 3 sec., "LOCK" is disappeared and the display shift to previous display. All keys become locked (pressing them will have no effect).

Press <SET>key continuously for about 3sec. again to release Lock mode. The "LOCK" indicator goes off and the lock mode is released (unlocked)

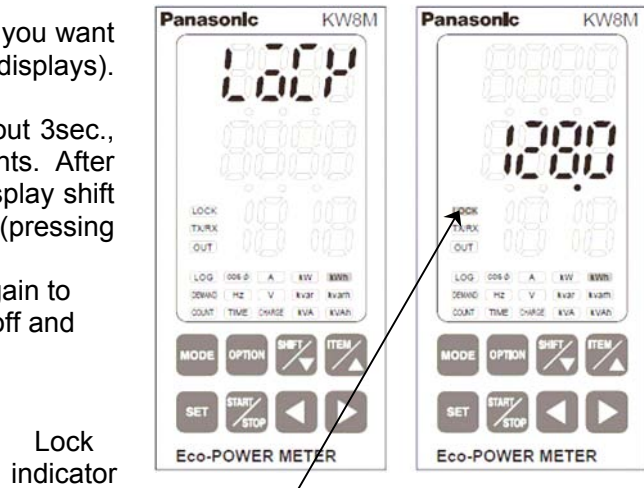

4-2 Display while communication

TX/RX indicator is blinking while Eco-POWER METER is under communication.

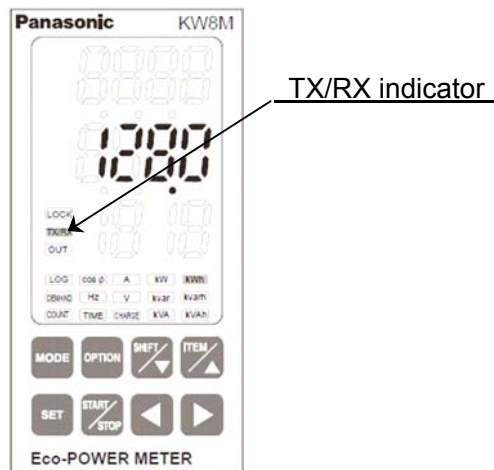

4-3 Display when pulse output

OUT indicator is lighting when pulse output.

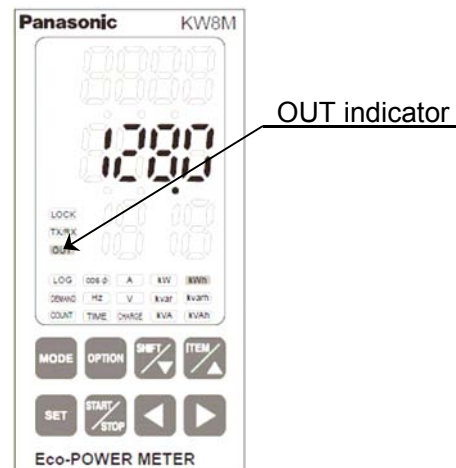

Chapter 5 Settings

5-1 Operation procedure

- MODE1: Setting for power measurement
- MODE2: Setting for pulse measurement

- MODE3: Setting for serial communication (RS485)
- MODE4: Setting for optional function

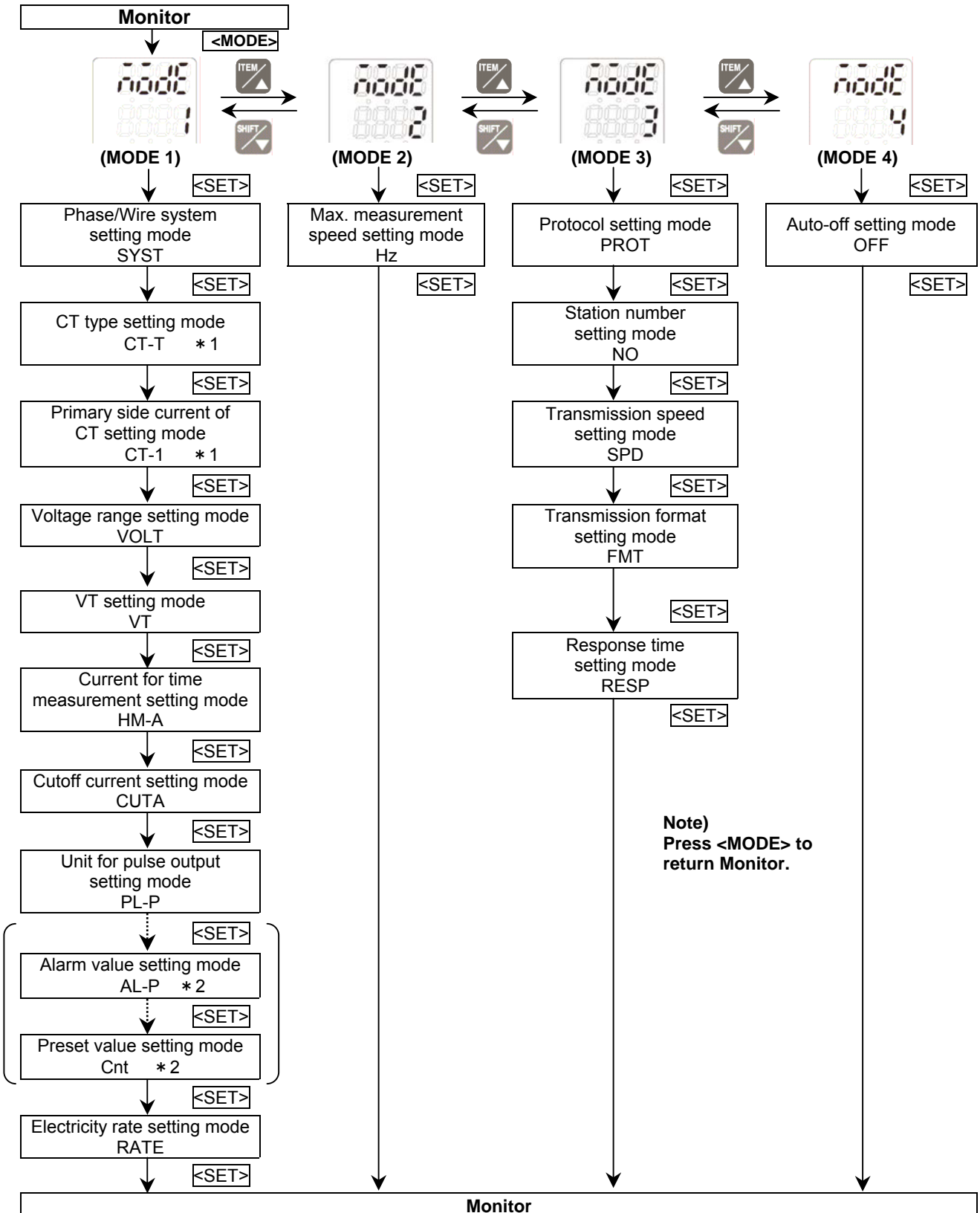

* 1 Primary side current of CT setting mode is only when '5A' is selected on CT type setting mode.

* 2 Alarm value setting mode/Preset value setting mode is only when 'ALARM' or 'Cnt' is selected on Unit for pulse output setting mode.

5-2 Setting Mode Explanation

■ The value with under line is initial setting among each setting value. ☆ Set before measurement.

5-2-1 MODE1

(Mode for setting each parameter for power measurement.)

Phase/Wire system setting mode SYST

Mode defines phase and wire system to measure.

• Select from Single-phase 2-wire / Single-phase 3-wire / Three-phase 3-wire / Three-phase 4-wire.

※ When Single-phase 3-wire or Three-phase 3-wire is selected, it doesn't measure Single-phase 2-wire system correctly. And when Three-phase 4-wire is selected, it doesn't measure Single-phase 2-wire, Single-phase 3-wire, Three-phase 3-wire system correctly. Select the accurate phase and wire system according to the measured system.

CT type setting mode CT-T

Mode defines input current type of the dedicated CT.

• Select from the type of 5A/50A/100A/250A/400A.

• When the secondary current of CT is 5A, select "5A".

Primary side current of CT setting mode CT-1

Mode defines primary side current when measuring by combination with existing CT, its secondary current of 5A.

It is possible to use as the second step for combination with existing CT by selecting "5A" in the CT type setting mode. In this case, it is necessary to set the primary side current.

• Primary side current of the existing CT can be set the range of 1 to 4000 (Initial 5).

• When connecting 5ACT directly and measure with 5A range, set to "5".

ex) If primary current of measured existing CT is 400A(secondary side is 5A), set to "400".

※ This mode is only when "5A" is selected on CT type setting mode.

Voltage range setting mode VOLT

Mode defines voltage range of Eco-Power Meter.

• Select from 400/200.

• When it measures load of 400V system, select "400".

When it measures load of 100/200V system, select "200".

※ In case measuring the load of 100/200V system with selecting "400", the resolution will be down.
Select the correct voltage range.

VT setting mode VT

Mode defines voltage input method to the main unit, input voltage directly or uses a voltage transformer (VT) (over 440V system).

• It can be set the range of 1.00 to 99.99.

"1.00" should be set when voltage input directly without connecting VT.

"1.01~99.99" should be set when VT is used to input voltage.

Current for time measurement setting mode HM-A

Mode defines for time measured current. It measures ON-time and OFF-time by setting value.

• It can be set the range of 1.0% to 100.0%F.S.

ex) When 10.0 is set, the current exceeds 10.0%F.S is measured as ON-time, the current under 10.0%F.S is measured as OFF-time.

※ Measured current is the current of L1(CT1)-phase.

Cutoff current setting mode CUTA

Mode defines load current that does not measured (Cutoff current).

Use to avoid miss-measurement by wiring or induction noise at no-load.

0.00kW is displayed for instantaneous electric power, 0.0A is displayed for current. Integrated electric power is not added.

• It can be set the range of 1.0% to 50.0%.

ex) When set to 10.0, current under 10.0%F.S is not added.

Unit for pulse output setting mode **PL - P**

Mode defines unit used for pulse output.

• Select from 0.001/0.01/0.1/1/10/100/AL-P/Cnt.

When one of the “0.001/0.01/0.1/1/10/100”[kWh] is set, one pulse is output at reaching the setting value.

When “AL-P” is set, alarm is output at the time when instantaneous active power is over the setting value.

When “Cnt” is set, it output at the time when count value reaches preset value set by preset value setting mode.

Alarm value setting mode **AL - P**

Mode defines instantaneous electric power used for alarm output.

• It is set the range of 0.00 to 999999.99kW.

※This mode is only when “AL-P” is selected on unit for pulse output setting mode.

Preset value setting mode **AL - P**

Mode defines count value used for output.

• It is set the range of 0 to 99999999.

※This mode is only when “Cnt” is selected on unit for pulse output setting mode.

Electricity charge setting mode **RATE**

Mode defines electricity charge ratio used as a standard per 1kWh.

• It can be set the range of 0.00 to 99.99 /1kWh. (Initial 10.00)

Mode1 Setting flow chart

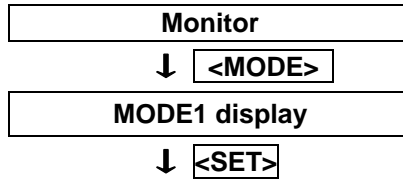

Phase/Wire system setting mode
 Press <Δ>, <∇> to change Phase/Wire system.
 System is selected from Single-phase 2-wire ⇔ Single-phase 3-wire ⇔ Three-phase 3-wire ⇔ Three-phase 4-wire.

1P2W 1P3W 3P3W 3P4W

CT type setting mode
 Press <Δ>, <∇> to change CT type.
 CT type is selected from 50 ⇔ 100 ⇔ 250 ⇔ 400 ⇔ 5.

50 100 250 400 5

Primary side current of CT setting mode
 Enter primary side current of CT using <Δ>, <∇>, <◀>, <▶>.
 If measured CT is 100A/5A, set to 100. If 5A is measured, set to 5.
 (1~4000, Initial 5)

- Increase value
- Decrease value
- Shift place to set
- Shift place to set

*It is only when "5A" is selected on CT type setting mode.

Voltage range setting mode

Press \triangle , ∇ to change voltage range.
Voltage range is selected from 400V \leftrightarrow 200V.



400V



200V

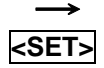

VT ratio setting mode

Enter VT ratio using \triangle , ∇ , \leftarrow , \rightarrow .
If the VT is 440/110, set to "4.00".



(1.00~99.99)



Increase value



Decrease value



Shift place to set



Shift place to set

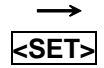

Current for time measurement setting mode

Enter current for time measurement using \triangle , ∇ , \leftarrow , \rightarrow .
If you measure the current over 50.0%F.S, set to "50.0".

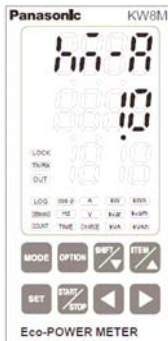

(1.0~100.0)



Increase value



Decrease value



Shift place to set



Shift place to set

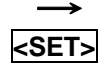

Cutoff current setting mode

Enter cutoff current using \triangle , ∇ , \triangleleft , \triangleright .

If you don't measure the current under 10.0%F.S, set to "10.0".

(1.0 ~50.0)

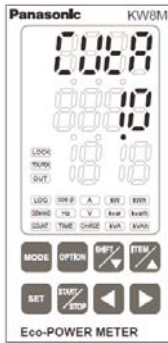

Increase value



Decrease value



Shift place to set



Shift place to set



Unit for pulse output setting mode

Press \triangle , ∇ to change unit for pulse output.

Unit is selected from 0.001 \leftrightarrow 0.01 \leftrightarrow 0.1 \leftrightarrow 1 \leftrightarrow 10 \leftrightarrow 100 \leftrightarrow AL-P(Alarm) \leftrightarrow Cnt (Count output).



0.001kWh



0.01kWh



0.1kWh

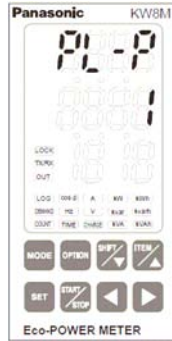

1kWh

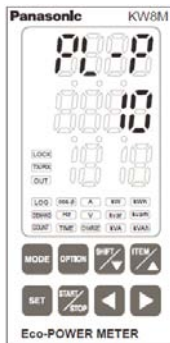

10kWh

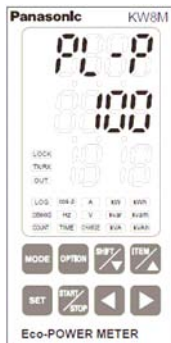

100kWh

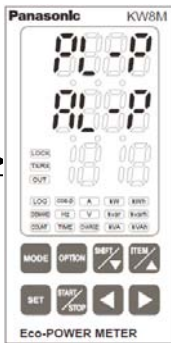

AL-P

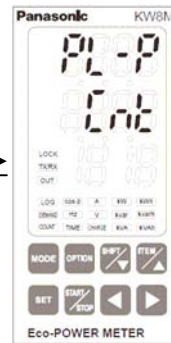

Cnt



Alarm value setting mode

Display changes to set an alarm value after "AL-P" is displayed at the upper line for 1 sec.

Enter power for alarm using \triangle , ∇ , \triangleleft , \triangleright .

(0.00~999999.99)

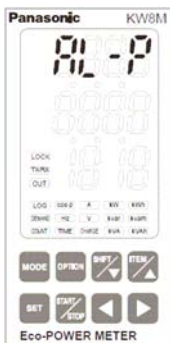

after
1 sec.

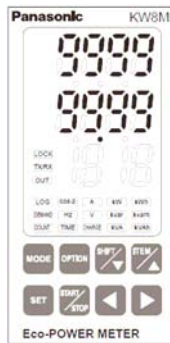

Increase value



Decrease value



Shift place to set



Shift place to set

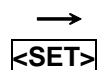

*It is only when "AL-P" is selected on unit for pulse output setting mode.



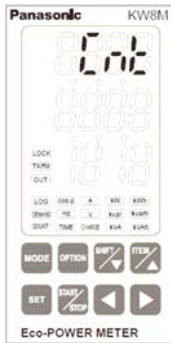

Preset value setting mode

Display changes to set an alarm value after "Cnt" is displayed at the upper line for 1 sec.
 Enter preset value to output using <Δ>, <∇>, <◀>, <▶>. (0 ~ 99999999)

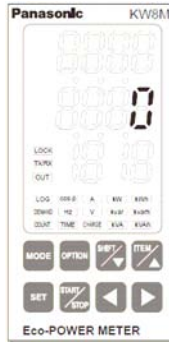

→
after
1 sec.







-  Increase value
-  Decrease value
-  Shift place to set
-  Shift place to set

→
<SET>

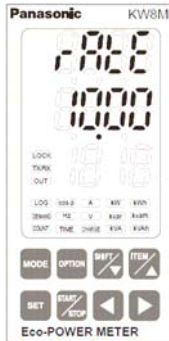
Electricity charge setting mode

Enter the rate per 1kWh using <Δ>, <∇>, <◀>, <▶>.
 (0.00~99.99, Initial 10.00)



-  Increase value
-  Decrease value
-  Shift place to set
-  Shift place to set

↓ **<SET>**

Monitor

5-2-2 MODE2

(Mode for setting of each parameter for pulse measurement)

Max. counting speed setting mode Hz

Mode defines max. counting speed.

• Select from 2kHz/30Hz

MODE2 Setting flow chart

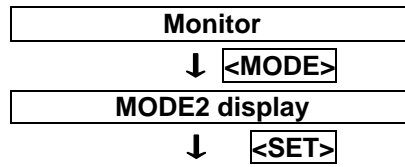

Max. counting speed setting mode

Press <Δ>, <∇> to change max. counting speed.

Max. counting speed is selected from 2000 (2kHz) ⇔ 30(30Hz).

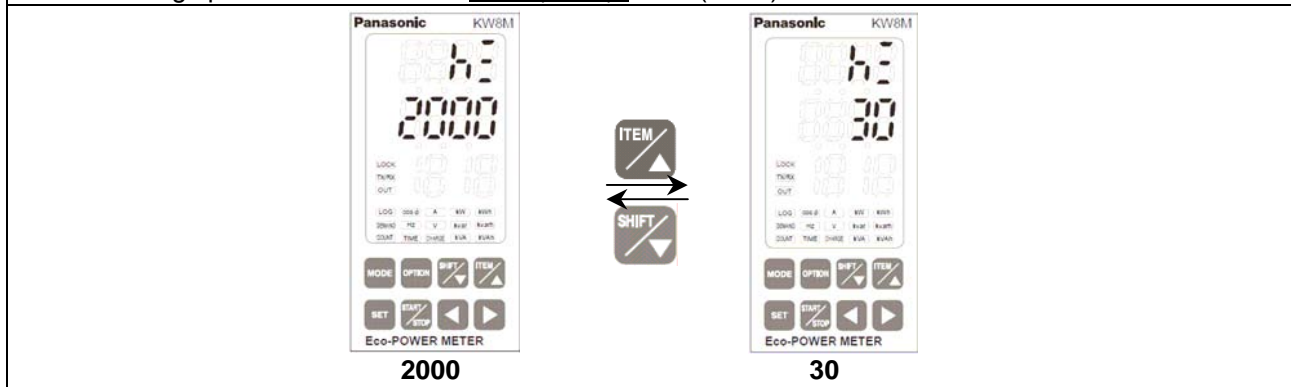

↓ <SET>

Monitor

5-2-3 MODE3

(Mode for setting of each parameter for serial communication (RS485))

Protocol setting mode **PROT**

Mode defines communication protocol of main unit via serial communication (RS485).

- Select from MEWTOCOL / MODBUS(RTU).

Station number setting mode **NO.**

Mode defines an individual station no. for each unit when two or more units communicate via serial communication (RS485).

- It can be set the range of 01 to 99.

Transmission speed (Baud rate) setting mode **SPD**

Mode defines serial communication (RS485) transmission speed. Define the transmission speed according to the master's (PLC etc.).

- Select from 19200/9600/4800/2400 [bit/s].

Transmission format setting mode **FMT**

Mode defines serial communication (RS485) transmission format (Data length, Parity). Define the transmission format according to the master's (PLC etc).

- Select from 8bit-o/7bit-n/7bit-E/7bit-o/8bit-n/8bit-E.

“n (none)” means parity is not available.

“E (Even)” means parity is even number.

“o (odd)” means parity is odd number.

※With MODBUS(RTU) protocol, it works only with 8bit.

Response time setting mode **RESP**

Mode defines serial communication (RS485) response time of main unit.

When command is received, it sends response after setting response time passes.

- It can be set the range of 5 to 99 ms.

MODE3 Setting flow chart

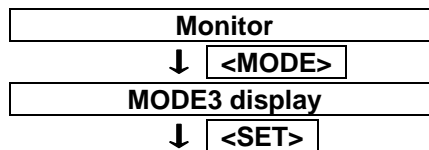

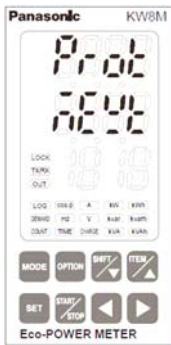

Protocol setting mode

Press <Δ>, <∇> to change communication protocol.
Communication protocol is selected from MEWTOCOL ⇔ MODBUS(RTU).



MEWTOCOL





MODBUS (RTU)

→

<SET>

Station number setting mode

Enter the station number using <Δ>, <▽>, <◀>, <▶>.
 Station number can be entered the range of 1 to 99.

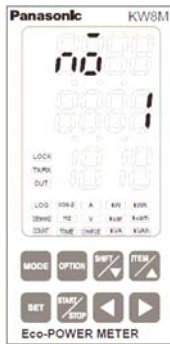

- Increase value
- Decrease value
- Shift place to set
- Shift place to set

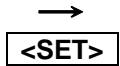

Transmission speed setting mode

Press <Δ>, <▽> to change transmission speed.
 Transmission speed is selected from 19200 ⇔ 2400 ⇔ 4800 ⇔ 9600.



19200bps

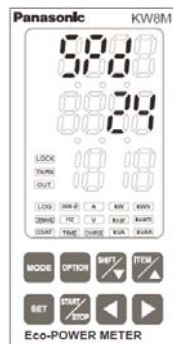

2400bps



4800bps

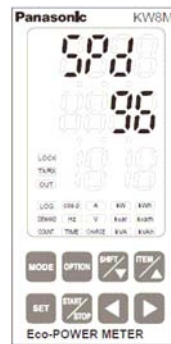

9600bps

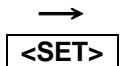

Transmission format setting mode

Press <Δ>, <▽> to change transmission format (Data length / Parity).
 Transmission format is selected from 8bit-o ⇔ 7bit-n ⇔ 7bit-E ⇔ 7it-o ⇔ 8bit-n ⇔ 8bit-E.
 n: not available E: even number o: odd number



8bit-o



7bit-n



7bit-E



7it-o

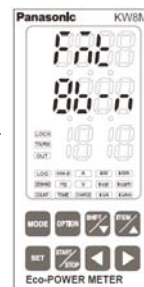

8bit-n



8bit-E

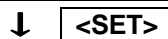

Response time setting mode

Set the response time using <Δ>, <▽>, <◀>, <▶>.
Response time can be entered the range of 5 to 99 ms.

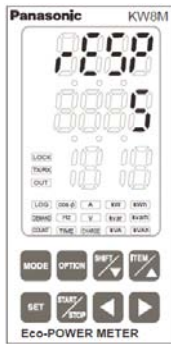

Increase value



Decrease value



Shift place to set



Shift place to set



<SET>

Monitor

5-2-4 MODE4

(Mode for setting of each parameter for optional function)

Auto-off setting mode **OFF**

Display LED turns off automatically when there is no key operation for a long time.

- Off time can be set the range of 0 to 99min.
- “0” should be set if you want to turn always light on.
- “1~99” should be set if you want to turn light off at setting time.
- After turns off the backlight, any key operation makes it turns on.
- After turns off the backlight, one decimal point at the right end is blinking.

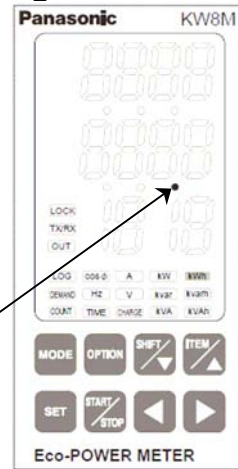

Decimal point (Right end)

MODE4 Setting flow chart

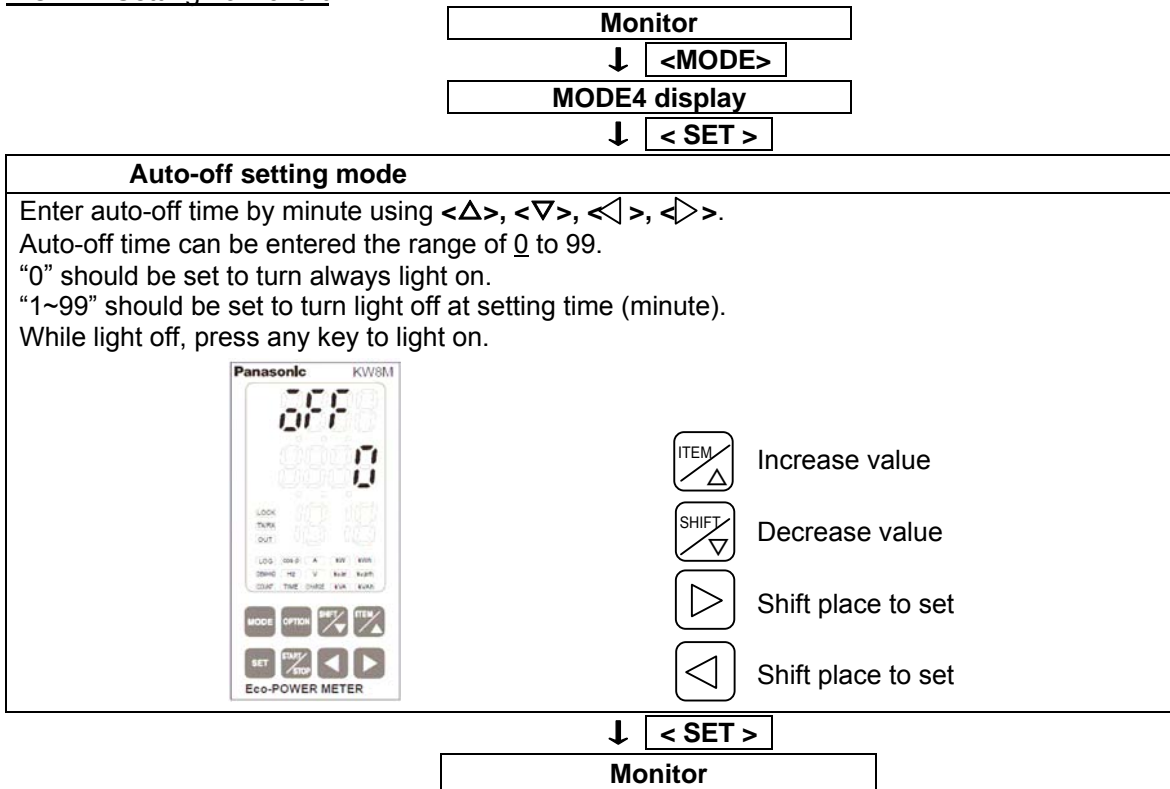

Chapter 6 Wiring

6-1 Main unit terminal arrangement

Function		No.		Function	
GND		①	⑪	P1	Measured voltage input
Power supply	L	②	⑫	P0	
	N	③	⑬	P2	
Pulse input	+	④	⑭	P3	Measured CT input
	-	⑤	⑮	CT1 (+)	
Pulse output	+	⑥	⑯	CT1 (-)	
	-	⑦	⑰	CT2 (+)	
RS485	+	⑧	⑱	CT2 (-)	
	-	⑨	⑲	CT3 (+)	
	E	⑩	⑳	CT3 (-)	

Back view		
①		⑪
②		⑫
③		⑬
④		⑭
⑤		⑮
⑥		⑯
⑦		⑰
⑧		⑱
⑨		⑲
⑩		⑳

⚠ The input voltage to each terminal is as follows.

Terminal	Phase and wire	Terminal	Input voltage
Operating power supply	Single-phase, two-wire	②—③	100-240VAC (100 - 240V~) (Line voltage)
Measured voltage input	Single-phase, two-wire	⑪—⑫	0-440VAC (0-440V~) (Line voltage)
	Single-phase, three-wire	⑪—⑫—⑬	0-220VAC (0-220V~ : 3W) (Phase voltage)
	Three-phase, three-wire	⑪—⑫—⑬	0-440VAC (0-440V 3~) (Line voltage)
	Three-phase, four-wire	⑪—⑫—⑬—⑭	0-254VAC (0-254V 3N~) (Phase voltage)

Caution for Wiring

- Terminal fastening torque should be **0.6 to 1.0N·m**.
- This has no built-in power switch, circuit breaker for power supply part. To protect the device, it is necessary to install power switch and circuit breaker in the power supply circuit.
And this has no built-in power switch, circuit breaker or fuse for measured voltage input parts.
Therefore it is necessary to install them in the circuit near this unit.
- The terminal block of KW8M is designed to be wired from left. Insert wires to the terminal from the left and fasten with terminal screws.
- In case using insulation sleeve, use an insulation sleeve applicable to M3 screw. Fastening torque should be 0.6 to 1.0N·m. (Refer to the below.)

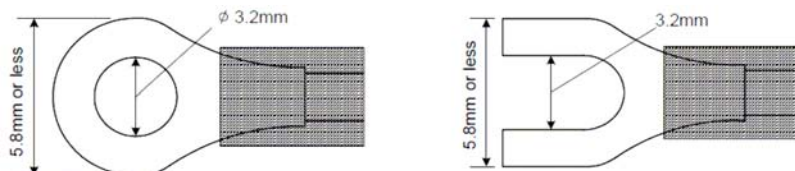

6-2 Wiring Diagrams

- Please connect a breaker to the voltage input part for safety reasons and to protect the device.
- Grounding CTs' secondary side (ℓ line) is recommended for the unit protection when CT break down.

Single-phase two-wire system

* One current transformer (CT) is required to measure single-phase two-wire system.

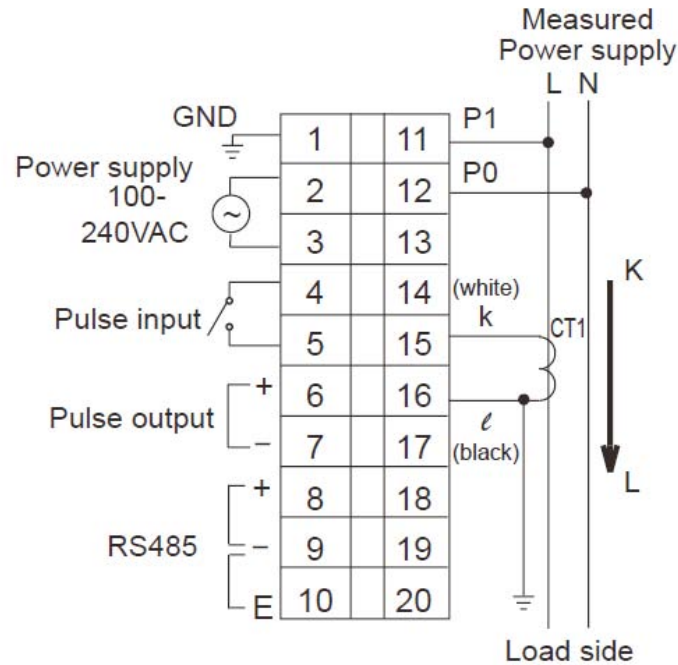

Single-phase three-wire

- * Two CTs are required to measure single-phase three-wire system.
- * Wire by diagram of single-phase 2-wire system when measure load using R-S with single-phase 3-wire system.

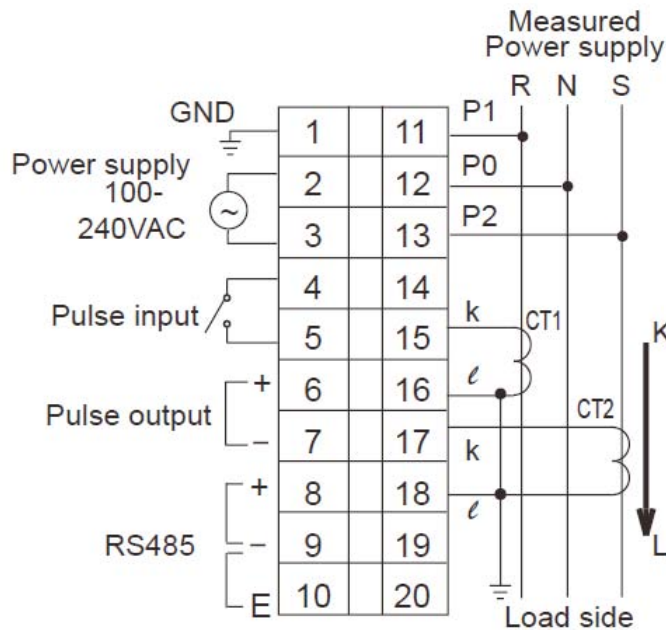

Three-phase three-wire system

* Two CTs are required to measure three-phase three-wire system.

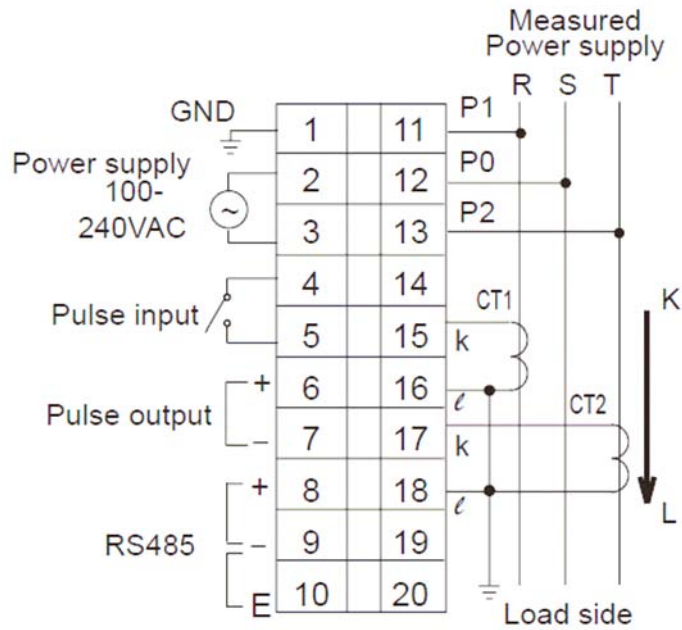

Three-phase four-wire system

* Three CTs are required to measure three-phase four-wire system.

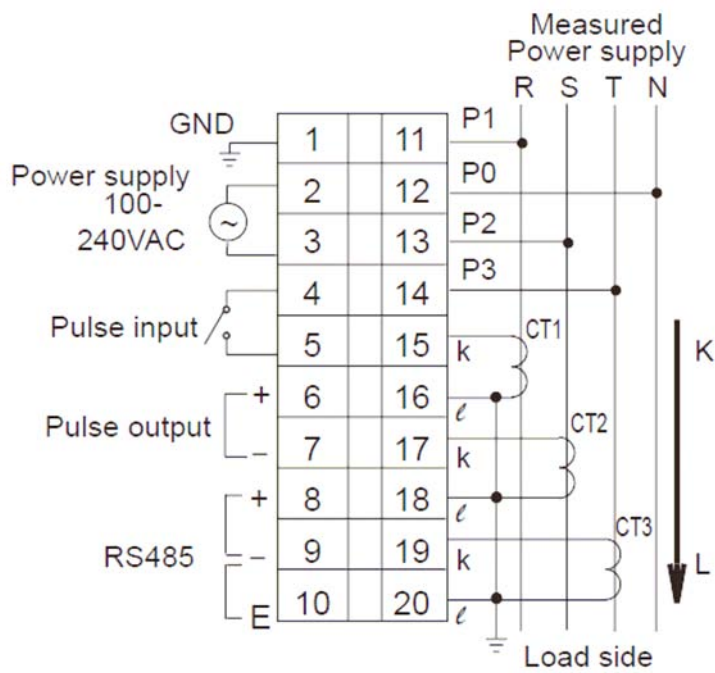

◇VT (Voltage transformer) is needed when you measure a load with voltage over 440V system.

Use commercial VT, those secondary rating is 110V.

*Grounding CT's secondary side (*ℓ* line) and VT's neutral line is recommended for the unit protection when CT or VT breaks down.

Single-phase two-wire system

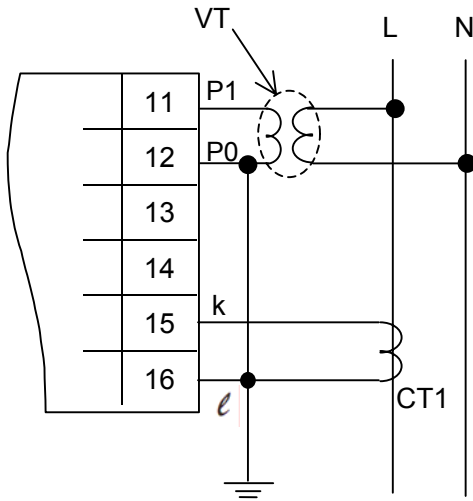

No.13,14,17~20 are not wired.

Single-phase, three-wire

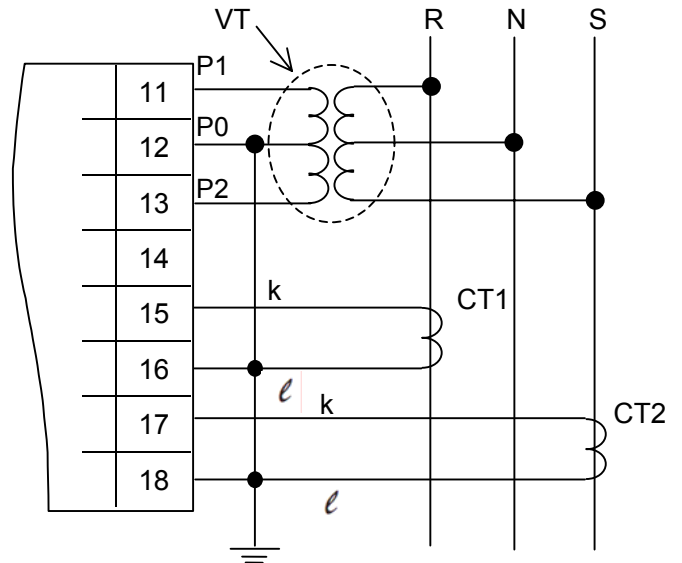

No.14, 19, 20 are not wired.

Three-phase, three-wire system

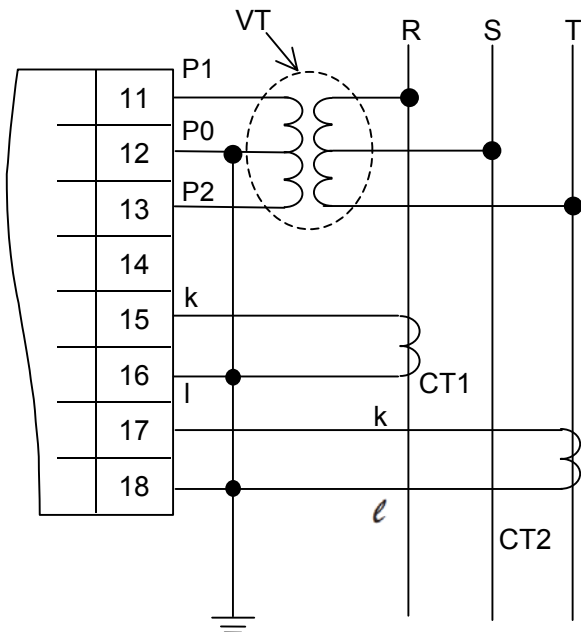

No.14, 19, 20 are not wired.

Three-phase, four-wire system

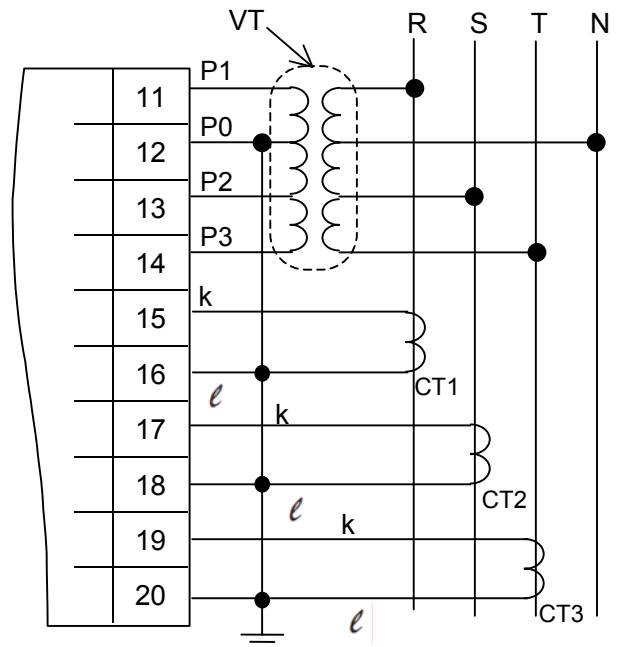

◇How to attach the Current Transformer (CT)

- One current transformer (CT) is required to measure a single-phase, two-wire system.
- Two CT are required to measure a single-phase, three-wire system or three-phase, three-wire system.
- Three CT are required to measure a three-phase, four-wire system.
- When connecting CT, connect the secondary side to the terminal of the main unit first, and after that wire the primary side to a load electric wire.
- The CT has polarity. Wire correctly according to the K and L marks. If it is wired wrong, it can not measure correctly.
- For the dedicated CT, 'k' is the white wire and 'ℓ' is the black wire.
- Check beforehand that the thickness of the electric wire is smaller than the through-hole of the CT. If you use a CT that separates at the bottom, make sure it is closed securely once the wire is in place; if not an error in measurement will occur.
- When CT's cable is extended, it is possible to extend up to about 10m with the cable of 0.75mm² or more cross section under the environment without noise at all. Please use the thick cable as much as possible.

◇To connect CT with secondary current 5A

How to connect the unit to measure by combination with existing commercial CT

- (1) Select 5A at CT type setting mode (CT-T).
- (2) Set the primary current of measured commercial CT (secondary current 5A) at primary side current of CT setting mode (CT-1).
< ex > If the measured CT is 400A/5A, set to "400".
- (3) Clamp the dedicated CT for 5A (AKW4801), which is connected to the main unit first, to secondary side of the commercial CT. CT direction (K→L) should be set for the commercial CT direction.

(Connection example)

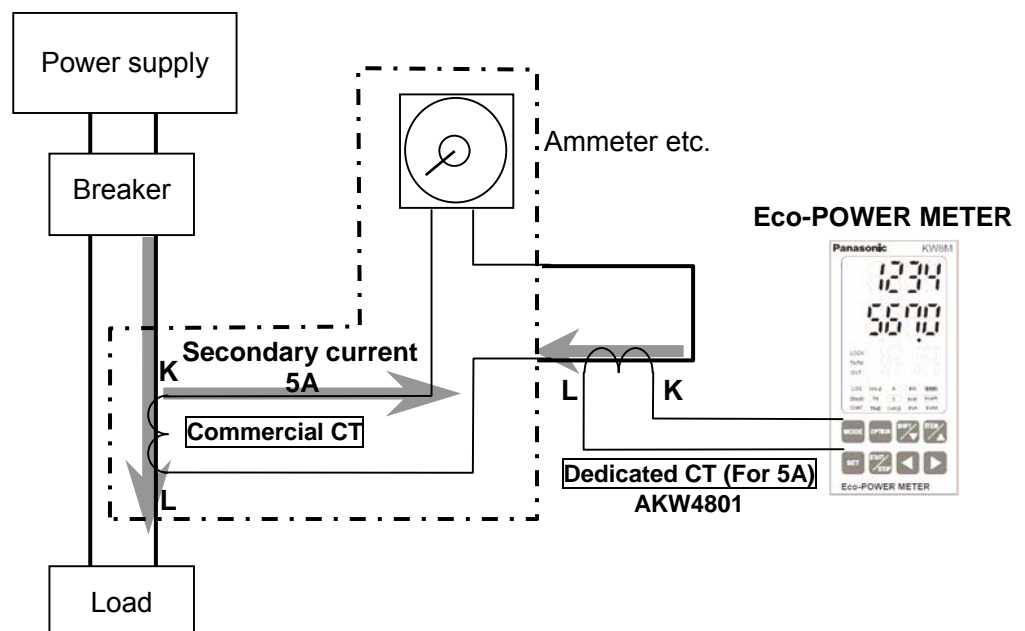

6-3 For input connection

◇Input connection

•Contact input

Use highly reliable metal plated contacts. Since the contact's bounce time leads directly to error in the count value, use contacts with as short a bounce time as possible. In general, select 30Hz for max. counting speed.

•Non-contact input (Transistor input)

Connect with an open collector. Use the transistor with the following specifications.

$V_{CE0}=20V$ min. $I_C=20mA$ min. $I_{CBO}=6\mu A$ max

Use transistors with a residual voltage of less than 1.5V when the transistor is ON.

※Short-circuit impedance should be less than $1k\Omega$.

(When the impedance is 0Ω , drain current is approx. 7mA.)

Open-circuit impedance should be more than $100k\Omega$.

•Input wiring

Please wire as short as possible by using a shielded wire or a metallic electric wire tube individually.

(Caution)

Operating power supply input part and measured voltage input are not insulated to pulse input parts. So the input equipment must have the power supply transformer in which the secondary side is not grounded with the primary and secondary sides insulated, in order to prevent interference of the power supply circuit when connecting the external input circuit. Be sure not to use an auto-transformer.

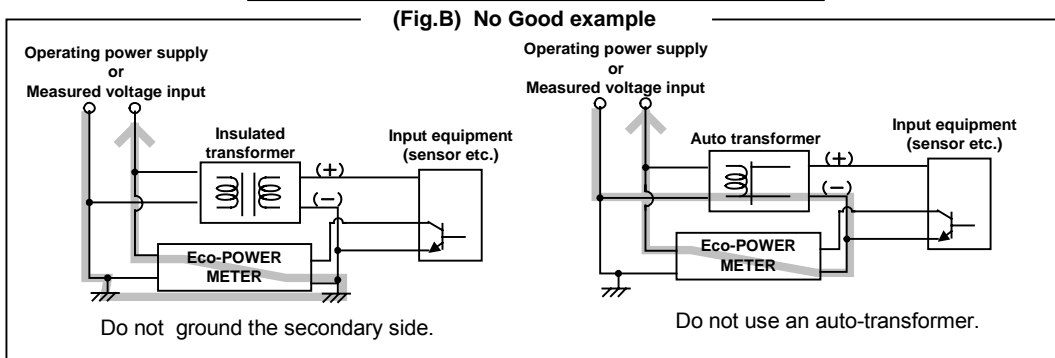
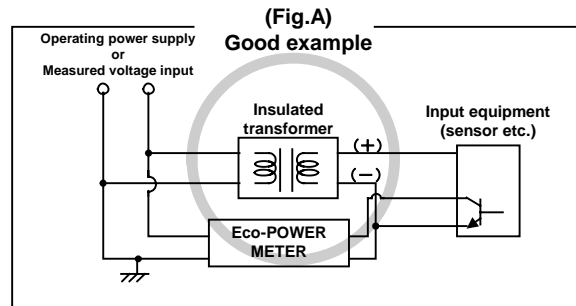

6-4 For Output connection

Since the transistor output is insulated from the internal circuit by a photo-coupler, it can be used both as a NPN output and PNP (equal value) output.

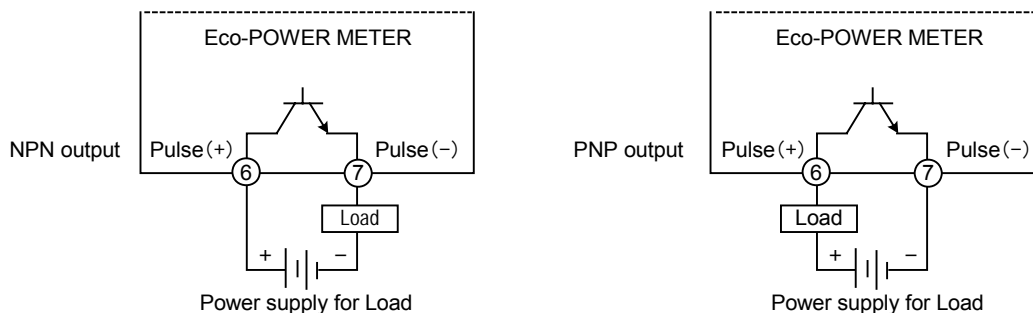

6-5 RS485 Communication

- When using shielded cable for the RS485 transmission line, ground one end.
Use a class D dedicated earth for grounding. Do not share a ground with other earth lines. (Fig.1)
- Be sure to connect with daisy chain the RS485 transmission line between each unit.
Do not use a splitter. (Fig.2)
- With a terminal station, RS485 (E) (No.10) and RS485 (-) (No.9) should be shorted.

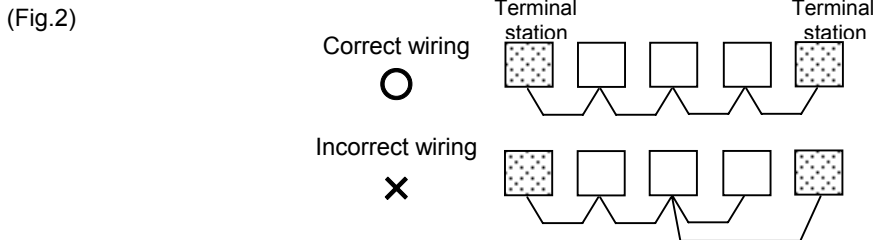
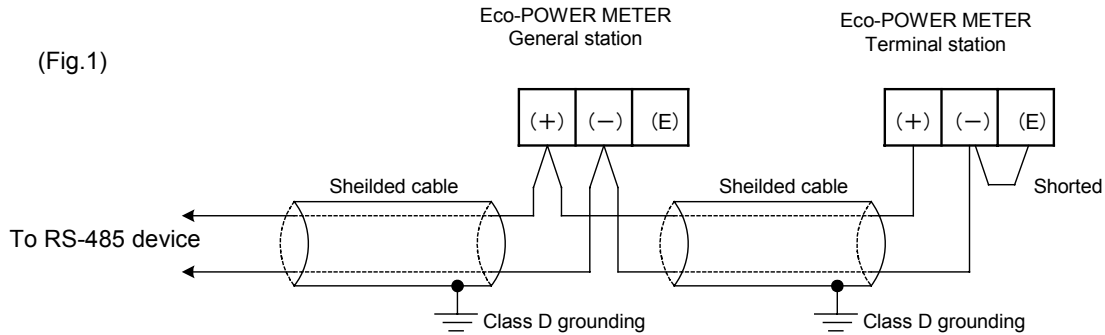

Recommended Cable

Use the transmission cables shown below for Eco-POWER METER RS485 communication system.

Cable	Conductor		Insulator		Cable diameter	Applicable cable
	Size	Resistance (at 20°C)	Material	Thickness		
Twisted-pair with shield	1.25 mm ² (AWG16) or more	Max.16.8Ω/km	Polyethylene	Max. 0.5 mm	Approx. 8.5 mm	HITACHI KPEV-S 1.25 mm ² × 1P Belden Inc. 9860
	0.5 mm ² (AWG20) or more	Max.33.4Ω/km	Polyethylene	Max. 0.5 mm	Approx. 7.8 mm	HITACHI KPEV-S 0.5 mm ² × 1P Belden Inc. 9207
VCTF	0.75 mm ² (AWG18) or more	Max.25.1Ω/km	PVC	Max. 0.6 mm	Approx. 6.6 mm	VCTF 0.75 mm ² × 2C (JIS)

Cable	Section
Twisted-pair with shield	
VCTF	

Notes

- 1) Use shielded type twist cables.
- 2) Use only one type of the transmission cables.
Do not mix different types of the cables.
- 3) Use twist pair cables under a bad noise environment.

6-6 Low Voltage Directive

When using in the application conforming to EN61010-1/IEC61010-1, make sure to satisfy the following conditions.

- (1) Pulse output part and communication part secure only basic insulation. In order to secure reinforced (double) insulation demanded by EN 61010-1/ IEC61010-1, secure basic insulation or more with load side for output part and secure basic insulation or more with communication system side for communication part.
- (2) Provide the voltage input part with an EN60947-1 or EN60947-3 compliant circuit breaker. The breaker that connects to the voltage input part must arrange at the position easily reached, and display shows it is the breaker of the equipment.
- (3) Use a wire with basic insulation or more for a wire cramped (or connected) CT.

【Environmental conditions】

- Overvoltage category II, Pollution degree 2
- Indoor use
- An ambient temperature of -10 to 50°C
- An ambient non-condensing humidity of 35 to 85%RH (at 20°C)
- Altitude of 2000m or less

【Mount the product in a place with】

- A minimum of dust, and an absence of corrosive gases
- No flammable, explosive gasses
- Few mechanical vibrations or shocks
- No exposure to direct sunlight
- No large capacity electromagnetic switches or cables through which large current is flowing

Chapter 7 MEWTOCOL Communications

7-1 Communication Procedures

Communication starts with command transmission from the host computer (hereafter Master) and ends with the response of Eco-POWER METER (hereafter Slave).

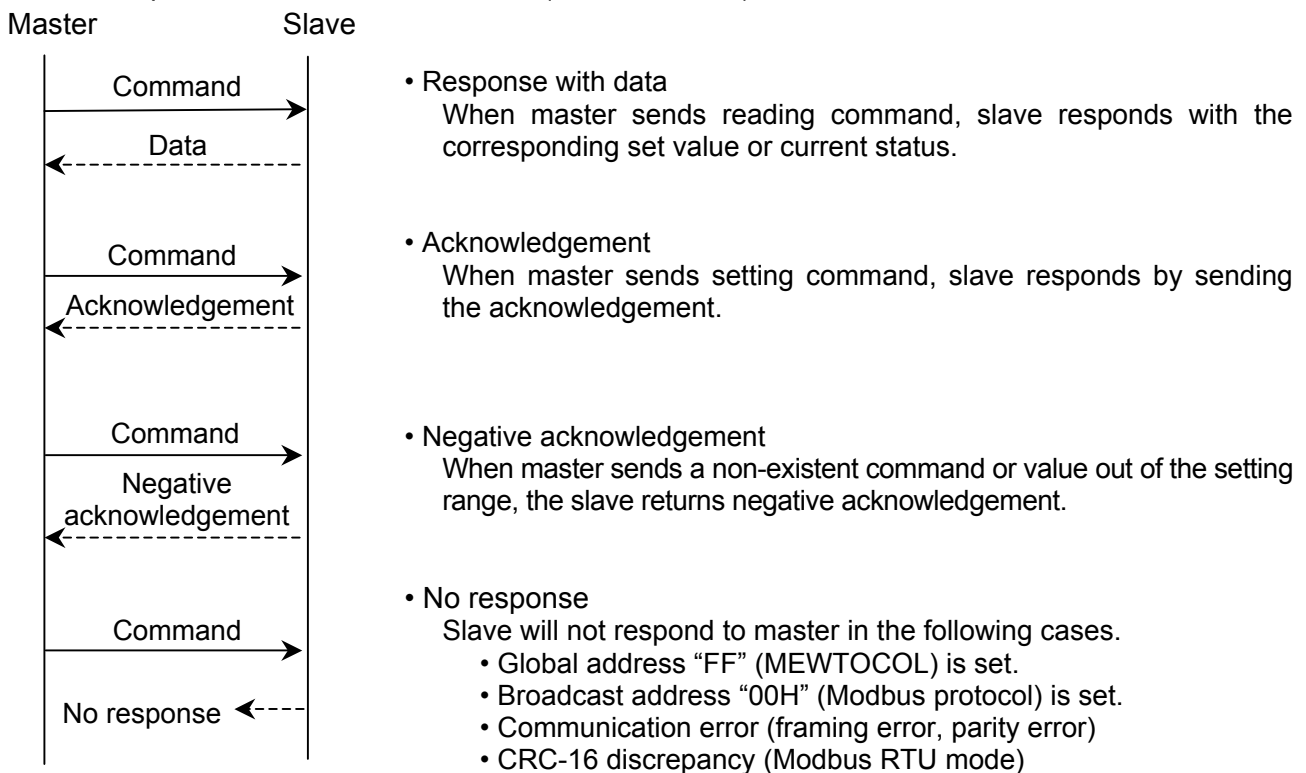

7-2 Communication timing

- ◆ The minimum access time from the master is 1 sec. (Minimum time for update the data)
Eco-POWER METER may not response due to noise and so on, be sure to check that it receives the response from Eco-POWER METER.
- ◆ In order to improve the communication quality, we recommend to send the transmission again.

Communication timing of RS485

◇ Eco-POWER METER (Slave) side

When Eco-POWER METER (Slave) starts transmission to RS485 communication line, it is arranged so as to provide an idle status transmission period of about 5 to 99ms (setting available)+Tb before sending the response to ensure the synchronization on the receiving side. After sending the response, master can disconnect the transmitter from the communication line within transmission period 20ms.
(Tb: Transmission period may be longer (0 to 60ms) due to Eco-POWER METER's process.)

◇ Master side (Cautions of setting a program)

At communication, keep the following conditions.

- 1) Set the program so that the master can disconnect the transmitter from the communication line within the transmission period of about 2ms after sending the command in preparation for reception of the response from Eco-POWER METER (Slave).
- 2) To avoid collision of transmissions between the master and Eco-POWER METER (Slave), send a next command after checking that the master received the response.

7-3-2 Data Register List

Data register	Name	Unit	Kind of data	Range	R/W
DT00050	Rate	0.01	Sign-less 16bit	0 to 9999	R/W
DT00060	CT type	Rated A (rms)	Sign-less 16bit	5 types: 5,50,100,250,400	R/W
DT00061	Unit for Pulse output	—	Sign-less 32bit	1(0.001),10(0.01),100(0.1),1000(1),10000(10),100000(100) 999 (Instantaneous electric power: Values of DT00064, 00065) 555 (Count value for output: Values of DT00154,00155)	R/W
DT00062					
DT00063	Primary side current value when CT 5A	1A	Sign-less 16bit	1 to 4000	R/W
DT00064	Alarm value (Instantaneous active power)	0.01kW	Sign-less 32bit	0 to 999999999	R/W
DT00065					
DT00066	VT ratio	0.01	Sign-less 16bit	100 to 9999	R/W
DT00067	Current threshold for time measurement	0.1%	Sign-less 16bit	1 to 1000	R/W
DT00068	Cutoff current	0.1%	Sign-less 16bit	10 to 500	R/W
DT00070	Voltage range	—	Sign-less 16bit	1; 400V 2; 200V	R/W
DT00100	Integrated active power	0.01kWh	Sign-less 32bit	0 to 999999999	R/W
DT00101					
DT00102	Integrated reactive power	0.01kvarh	Sign-less 32bit	0 to 999999999	R/W
DT00103					
DT00104	Integrated apparent power	0.01kVAh	Sign-less 32bit	0 to 999999999	R/W
DT00105					
DT00107	Current L1A(CT1)	0.1A	Sign-less 16bit	0 to 60000	R
DT00108	Current L2A(CT2)	0.1A	Sign-less 16bit	0 to 60000	R
DT00109	Current L3A(CT3)	0.1A	Sign-less 16bit	0 to 60000	R
DT00111	Power factor	0.01	Sign-less 16bit	0 to 100	R
DT00112	Frequency	0.1Hz	Sign-less 16bit	0 to 1000	R
DT00150	Load ON-time	0.1h	Sign-less 32bit	0 to 999999	R/W
DT00151					
DT00152	Load OFF-time	0.1h	Sign-less 32bit	0 to 999999	R/W
DT00153					
DT00154	Pulse count value	—	Sign-less 32bit	0 to 999999999	R/W
DT00155					
DT00158	Preset value	—	Sign-less 32bit	0 to 999999999	R/W
DT00159					
DT00162	Max. counting speed	Hz	Sign-less 16bit	30, 2000	R/W
DT00163	Auto-off time	min	Sign-less 16bit	0 to 99 (0:always on)	R/W
DT00170	Voltage L1V (Between P1-P0)	0.1V	Sign-less 32bit	0 to 99999	R
DT00171					
DT00172	Voltage L2V (Between P2-P0)	0.1V	Sign-less 32bit	0 to 99999	R
DT00173					
DT00174	Voltage L3V (Between P3-P0)	0.1V	Sign-less 32bit	0 to 99999	R
DT00175					
DT00176	Instantaneous active power	0.01kW	Sign-less 32bit	0 to 999999999	R
DT00177					
DT00178	Instantaneous reactive power	0.01kvar	Sign-less 32bit	0 to 999999999	R
DT00179					
DT00180	Instantaneous apparent power	0.01kVA	Sign-less 32bit	0 to 999999999	R
DT00181					

Note1) R: Read W: Write

2) Data register except specified is 0.

3) DT00061, 00062 (Unit for pulse output) is numerical value (in the range of data register).

4) If each setting value is wrote by communication, it memories to internal EEP-ROM at the same time. Therefore, change setting frequently makes EEP-ROM's life short. AVOID to usage like this.

5) Write a data within the range when you write it.

7-3-3 Error Codes

◇Basic procedure errors

Error code	Error name	Explanation
40H	Bcc error	• A Bcc error occurred in the command data.
41H	Format error	• A command message was sent that does not fit the transmission format.
42H	No support error	• A command was sent that is not supported.
43H	Procedure error	• Delimiter with multiple frames was sent. • The response shall be multiple frames.

◇Application error

Error code	Error name	Explanation
60H	Parameter error	• The data code is not "D".
61H	Data error	• Word No. is specified without decimal. (0000F etc.) • The starting word No. is bigger than the ending word No. • Writing data has a code that is not hexadecimal.
62H	Registration error	• Too many registrations have been entered (more than 17). • "MD" command was sent when some registration has been exist. • "MG" command was sent when registration has not been entered.

◇Self-diagnostic error

Error code	Error name	Explanation
45H	Operation error	• At "WD" command, writing data is exceeded the range of data register.

7-3-4 Command

Eco-POWER METER has 5 kinds of commands.

Command name	Code	Explanation
Read data area	RD	Reads the contents of data area.
Write data to data area	WD	Writes data to a data area.
Resister or Reset data monitored	MD	Resisters the data to be monitored.
Monitoring start	MG	Monitors a registered data.
Read status	RT	Reads the specifications of Eco-POWER METER and error code if an error occurs.

◆[RD]: Read data area (Reads the contents of data area.)

◇Command

%	Destination	#	R	D	D	Starting word No. 5 characters					Ending word No. 5 characters					Bcc	CR	
	$\times 10^1$	$\times 10^0$				$\times 10^4$	$\times 10^3$	$\times 10^2$	$\times 10^1$	$\times 10^0$	$\times 10^4$	$\times 10^3$	$\times 10^2$	$\times 10^1$	$\times 10^0$	$\times 16^1$	$\times 16^0$	

◇Normal response (Read successful)

%	Source	\$	R	D	First register contents 4 characters				Last register contents 4 characters				Bcc	CR	
	$\times 10^1$	$\times 10^0$			$\times 16^1$	$\times 16^0$	$\times 16^3$	$\times 16^2$	$\times 16^1$	$\times 16^0$	$\times 16^3$	$\times 16^2$	$\times 16^1$	$\times 16^0$	
					(lower word) (higher word)				(lower word) (higher word)						

◇Error response

%	Source	!	Error code	Bcc	CR	
	$\times 10^1$	$\times 10^0$	$\times 16^1$	$\times 16^0$	$\times 16^1$	$\times 16^0$
						(Common to each command)

◆[WD]: Write data area (Writes date to a data area.)

◇Command

%	Destination	#	W	D	D	Starting word No. 5 characters					Ending word No. 5 characters					First writing data 4 characters				⇒
	$\times 10^1$	$\times 10^0$				$\times 10^4$	$\times 10^3$	$\times 10^2$	$\times 10^1$	$\times 10^0$	$\times 10^4$	$\times 10^3$	$\times 10^2$	$\times 10^1$	$\times 10^0$	$\times 16^1$	$\times 16^0$	$\times 16^3$	$\times 16^2$	
						(lower word) (higher word)				(lower word) (higher word)										

◇Normal response (Write successful)

%	Source	\$	W	D	Bcc	CR								
	$\times 10^1$	$\times 10^0$			$\times 16^1$	$\times 16^0$								
							⇒	Last writing data 4 characters				Bcc	CR	
								$\times 16^1$	$\times 16^0$	$\times 16^3$	$\times 16^2$	$\times 16^1$	$\times 16^0$	
								(lower word) (higher word)						

◆ **[MD]: Register or Reset data monitored (Registers the data to be monitored.)** *Up to 16 points can be registered for one unit.

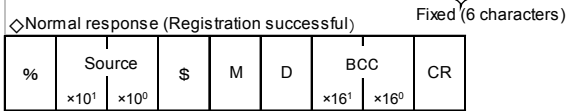
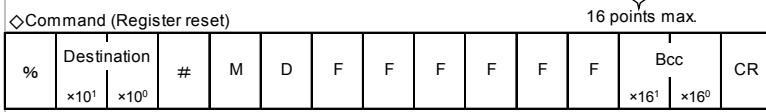
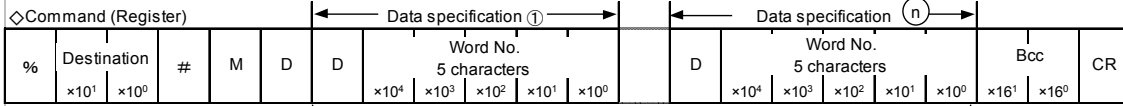

◆ **[MG]: Monitoring start (Monitors a registered data.)**

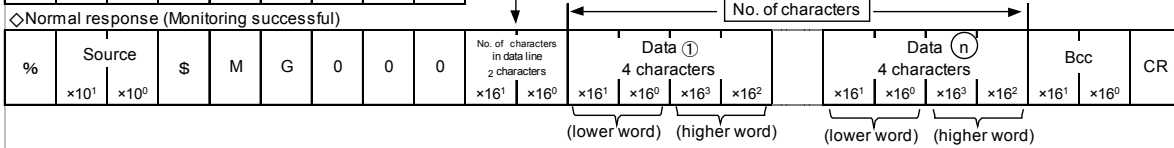
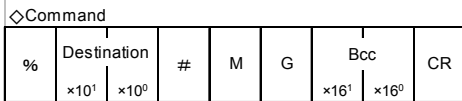

◆ **[RT]: Read the status of Eco-POWER METER (Reads the specifications of Eco-POWER METER and error codes if an error occurs.)**

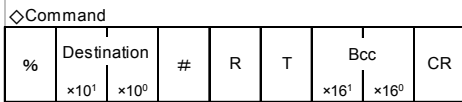

Operation mode
01: On operating
00: Stop

Error flag
01: abnormal
00: normal

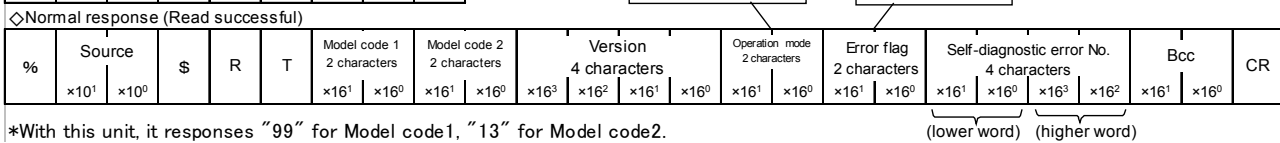

*With this unit, it responds "99" for Model code1, "13" for Model code2.

- note1) Even if it commands to write to non-existent data address, slave response with acknowledgement. However, it doesn't write.
- note2) Even if it commands to write the value out of the setting range, slave response with acknowledgement. However, it doesn't write.
- note3) The maximum number of reading slaves is 26 (57-bite), the maximum number of writing slaves is 23 (55-bite).

7-4 MODBUS (RTU) Communication

7-4-1 Overview of MODBUS (RTU)

◆8-bit binary data in command is transmitted as it is.

Data format	Start bit	: 1 bit
	Data bit	: 8 bits ※7bits is not available.
	Parity	: No parity, Even parity, Odd parity Selectable
	Stop bit	: 1 bit (Fixed)
	Error detection	: CRC-16 (Cyclic Redundancy Check)
	Data interval	: 3.5 character transmission time or less

◆Message configuration

RTU mode is configured to start after idle time processing of more than 3.5 character transmissions and end after idle time processing of more than 3.5 character transmissions.

3.5 idle characters	Slave address	Function code	Data	Error check CRC-16	3.5 idle characters
	8-bit	8-bit	* * bits	16-bit	

Master judges the transmission complete after no command for 4-characters idle time and process the command.

*Transmission speed and judgement time to complete transmission

Transmission speed (bps)	Judgement time to complete (ms)
19200	about 2.00
9600	about 4.00
4800	about 8.00
2400	about 16.00

◇Slave address:

Slave address is an individual instrument number on the slave side and is set within the range 1 to 99 (01H to 63H). Master identifies slaves by the slave address of the requested message.

Slave informs master which slave is responding to master by placing its own address in the response message. Slave address 0 (00H, broadcast address) can identify all slaves connected. However slaves do not respond.

◇Function code: Function code is command code for the slave to undertake the following action types.

Function code	Contents
03(03H)	DT Read
06(06H)	DT1 word write
16(10H)	DT several data write

Function code is used to discern whether the response is normal (acknowledgement) or if any error (negative acknowledgement) has occurred when slave returns response message to master.

When acknowledgement is returned, slave simply returns original function code. When negative acknowledgement is returned, MSB of original function code is set as 1 for response.

For example, when the master sends request message setting 00H to function code by mistake, slave returns 80H by setting MSB to 1, because the former is an illegal function.

For negative acknowledgement, the exception codes below are set to data of response message and returned to master in order to inform it of what kind of error has occurred.

Exception code	Contents
1(01H)	Illegal Function (Non-existent function)
3(03H)	Illegal data value (Value out of the device numbers)

note1) Even if it commands to write (06H.10H) to non-existent data address, slave response with acknowledgement. However, it doesn't write.

note2) Even if it commands to write the value out of the setting range, slave response with acknowledgement. However, it doesn't write.

note3) The maximum number of reading slaves is 26 (57-bite), the maximum number of writing slaves is 23 (55-bite).

◇Data: Data depends on the function code.

A request message from the master side is composed of data item, number of data and setting data.

A response message from the slave side is composed of number of bytes, data and exception code in negative acknowledgement.

◇Error check: 16-bit data to detect communication errors. Refer to the next.

◇Acknowledgement response

When command is to write 1 point, same message of command is responded.

When command is to write several points, part of command message (6-bite) is responded.

◆Error check

After calculating CRC-16 (Cyclic Redundancy Check) from slave address to the end of data, the calculated 16-bit data is appended to the end of message in sequence from low order to high order.

<How to calculate CRC>

In CRC system, the information is divided by the polynomial series. The remainder is added to the end of the information and transmitted. The generation of polynomial series is as follows.

(Generation of polynomial series: $X^{16} + X^{15} + X^2 + 1$)

- ① Initialize the CRC-16 data (assumed as X) (FFFFH).
- ② Calculate exclusive OR (XOR) with the 1st data and X. This is assumed as X.
- ③ Shift X one bit to the right. This is assumed as X.
- ④ When a carry is generated as a result of the shift, XOR is calculated by X of ③ and the fixed value (A001H). This is assumed as X. If a carry is not generated, go to step ⑤.
- ⑤ Repeat steps ③ and ④ until shifting 8 times.
- ⑥ XOR is calculated with the next data and X. This is assumed as X.
- ⑦ Repeat steps ③ to ⑤.
- ⑧ Repeat steps ③ to ⑤ up to the last data.
- ⑨ Set X as CRC-16 to the end of message in sequence from low order to high order.

◆Message example

① Reading electricity rate (0032H) of address 1

•Command

3.5 idle characters	Slave address (01H)	Function code (03H)	Data item (0032H)	Number of data (0001H)	Error check CRC-16 (25C5H)	3.5 idle characters
	1	1	2	2	2	←character number

•Response message from slave in normal status (When Rate=1000(10.00) [03E8H])

3.5 idle characters	Slave address (01H)	Function code (03H)	Number of response byte (02H)	Number of data (03E8H)	Error check CRC-16 (B8FAH)	3.5 idle characters
	1	1	1	2	2	←character number

② Setting electricity rate (0032H) of address 1 (When rate is set to 20.00(2000) [07D0H])

•Command

3.5 idle characters	Slave address (01H)	Function code (06H)	Data item (0032H)	Number of data (07D0H)	Error check CRC-16 (2BA9H)	3.5 idle characters
	1	1	2	2	2	←character number

•Response message from slave in normal status

3.5 idle characters	Slave address (01H)	Function code (06H)	Data item (0032H)	Number of data (07D0H)	Error check CRC-16 (2BA9H)	3.5 idle characters
	1	1	2	2	2	←character number

7-4-2 Data Register List

MODBUS Function code	Data item (MEWTOCOL)	Name	Unit	Kind of date	Range: Hexadecimal (Range: Decimal)
03H/06H/10H	0032H (DT00050)	Rate	0.01	Sign-less 16bit	0H~270FH (0~9999)
03H/06H/10H	003CH (DT00060)	CT type	Rated A (rms)	Sign-less 16bit	5 types: 5H(5), 32H(50), 64H(100), FAH(250), 190H(400)
03H/06H/10H	003DH (DT00061)	Unit for Pulse output	—	Sign-less 32bit	1H(1)<0.001>, AH(10)<0.01>, 64H(100)<0.1>, 3E8H(1000)<1>, 2710H(10000)<10>, 186A0H(100000)<100>, 3E7H(999) <Instantaneous electric power: Values of DT00064, 00065> 22B(555) <Count value for output: Values of DT00154,00155>
	003EH (DT00062)				
03H/06H/10H	003FH (DT00063)	Primary side current value when CT 5A	1A	Sign-less 16bit	1H~FA0H (1~4000)
03H/06H/10H	0040H (DT00064)	Alarm value (Instantaneous active power)	0.01kW	Sign-less 32bit	0H~5F5E0FFH (0~99999999)
	0041H (DT00065)				
03H/06H/10H	0042H (DT00066)	VT ratio	0.01	Sign-less 16bit	64H~270FH (100~9999)
03H/06H/10H	0043H (CT00067)	Current threshold for time measurement	0.1%	Sign-less 16bit	1H~3E8H (1~1000)
03H/06H/10H	0044H (DT00068)	Cutoff current	0.1%	Sign-less 16bit	AH~1F4H (10~500)
03H/06H/10H	0046H (DT00070)	Voltage range	—	Sign-less 16bit	1H(1):400V 2H(2):200V
03H/06H/10H	0064H (DT00100)	Integrated active power	0.01kWh	Sign-less 32bit	0H~3B9AC9FFH (0~999999999)
	0065H (DT00101)				
03H/06H/10H	0066H (DT00102)	Integrated reactive power	0.01kWh	Sign-less 32bit	0H~3B9AC9FFH (0~999999999)
	0067H (DT00103)				
03H/06H/10H	0068H (DT00104)	Integrated apparent power	0.01kWh	Sign-less 32bit	0H~3B9AC9FFH (0~999999999)
	0069H (DT00105)				
03H	006BH (DT00107)	Current L1A(CT1)	0.1A	Sign-less 16bit	0H~EA60H (0~60000)
03H	006CH (DT00108)	Current L2A(CT2)	0.1A	Sign-less 16bit	0H~EA60H (0~60000)
03H	006DH (DT00109)	Current L3A(CT3)	0.1A	Sign-less 16bit	0H~EA60H (0~60000)
03H	006FH (DT00111)	Power factor	0.01	Sign-less 16bit	0H~64H (0~100)
03H	0070H (DT00112)	Frequency	0.1	Sign-less 16bit	0H~3E8H (0~1000)

03H/06H/10H	0096H (DT00150)	Load ON-time	0.1h	Sign-less 16bit	0H~F423FH (0~999999)
	0097H (DT00151)				
03H/06H/10H	0098H (DT00152)	Load OFF-time	0.1h	Sign-less 16bit	0H~F423FH (0~999999)
	0099H (DT00153)				
03H	009AH (DT00154)	Pulse count value	—	Sign-less 32bit	0H~5F5E0FFH (0~999999999)
	009BH (DT00155)				
03H/06H/10H	009EH (DT00158)	Preset value	—	Sign-less 32bit	0H~5F5E0FFH (0~999999999)
	009FH (DT00159)				
03H/06H/10H	00A2H (DT00162)	Max. counting speed	Hz	Sign-less 16bit	1EH (30), 7D0H (2000)
03H/06H/10H	00A3H (DT00163)	Auto-off time	min	Sign-less 16bit	0H~63H (0~99)
03H	00AAH (DT00170)	Voltage L1V (Between P1-P0)	0.1V	Sign-less 32bit	0H~1869FH (0~99999)
	00ABH (DT00171)				
03H	00ACH (DT00172)	Voltage L2V (Between P2-P0)	0.1V	Sign-less 32bit	0H~1869FH (0~99999)
	00ADH (DT00173)				
03H	00AEH (DT00174)	Voltage L3V (Between P3-P0)	0.1V	Sign-less 32bit	0H~1869FH (0~99999)
	00AFH (DT00175)				
03H	00B0H (DT00176)	Instantaneous active power	0.01kW	Sign-less 32bit	0H~5F5E0FFH (000~999999999)
	00B1H (DT00177)				
03H	00B2H (DT00178)	Instantaneous reactive power	0.01kW	Sign-less 32bit	0H~5F5E0FFH (000~999999999)
	00B3H (DT00179)				
03H	00B4H (DT00180)	Instantaneous apparent power	0.01kW	Sign-less 32bit	0H~5F5E0FFH (000~999999999)
	00B5H (DT00181)				

note 1) 03H: Read 06H/10H: Write

note 2) Data register except specified is "0".

note 3) If each setting value is wrote by communication, it memories to internal EEP-ROM at the same time. Therefore, change setting frequently makes EEP-ROM's life short. Avoid to usage like this.

note 4) Write a data within the range when you write it.

Chapter 8 Specifications

8-1 Main unit

Rated operating voltage	100-240V AC	
Rated frequency	50/60Hz common	
Rated power consumption	8VA	
Allowable operating voltage range	85-264V AC (85%~110% of rated operating voltage)	
Allowable momentary power-off time	10ms	
Ambient temperature	-10 to +50°C(-25°C to +70°C at storage)	
Ambient humidity	30 to 85%RH(at 20°C non-condensing)	
Breakdown voltage(initial)	Between the isolated circuits: 2000V for 1min note) Cut-off current: 10mA However protective varistor excluded.	A)Outer edge (case)—All terminals B)Insulated circuit • GND—All other terminals • Operating power supply terminals— Analog input terminals • Operating power supply terminals— Pulse input terminal • RS485—All other terminals • Pulse output terminals— All other terminals note1)
Insulation resistance(initial)	Between the isolated circuits: 100MΩ or more (measured at 500V DC)	
Vibration resistance	10 to 55Hz (1cycle/min) single amplitude : 0.375mm(1h on 3 axes)	
Shock resistance	Min. 294m/s ² (5 times on 3 axes)	
Display method	8-digit, 7-segment LED	
Power failure memory method	EEP-ROM (more than 100,000 overwrite)	
Size	48 x 96 x 98.5 mm	
Weight	approx.235g (without mounting bracket)	

note1) Analog input terminals: No.11 to 20 / Pulse input terminal: No.4 and 5

8-2 Input Specifications

8-2-1 Electric power input

Measuring item	Power	Instantaneous active power (kW) Instantaneous reactive power (kvar) Instantaneous apparent power (kVA)	
		Integrated active power (kWh) Integrated reactive power (kvarh) Integrated apparent power (kVAh)	
	Voltage	Actual value Voltage (Between P1-P0, Between P2-P0, Between P3-P0) (V)	
	Current	Actual value Current (L1-phase current, L2-phase current, L3-phase current) (A)	
	Electricity charge	Integrated electricity charge	
Display range	Others		Power factor, Frequency
	Measured electric power (Active, Reactive, Apparent)	0.00 to 999999.99 (kW/ kvar/ kVA)	
	Integrated electric power (Active, Reactive, Apparent)	0.00 to 9999999.9 (kWh/ kvarh/ kVAh)	
	Voltage	0.0 to 9999V	
	Current	0.0 to 6000A	
	Electricity charge	0.00 to 99999999	
	Power factor	0.00 to 1.00	
Frequency	Rating	50.0 to 60.0Hz	
	Allowable	47.5 to 63.0Hz (95 to 105% of rating)	
Phase and wire system		Single-phase two-wire system Single-phase three-wire system (common) Three-phase three-wire system Three-phase four-wire system	
Measured input voltage	Rating	Single-phase two-wire : 0-440V AC (Line voltage) Single-phase three-wire : 0-220V AC (Phase voltage) Three-phase three-wire : 0-440V AC (Line voltage) Three-phase four-wire : 0-254V AC (Phase voltage)	
	Allowance	85% to 120% of rated input voltage	
	Allowable measurement voltage	Single-phase two-wire : 0-528V AC (Line voltage) Single-phase three-wire : 0-264V AC (Phase voltage) Three-phase three-wire : 0-528V AC (Line voltage) Three-phase four-wire : 0-300V AC (Phase voltage)	
	VT ratio	1.00 to 99.99 (Set with setting mode) ※Voltage transformer (VT) is required when you measure a load with voltage over 440V system. ※Secondary current rating of commercial VT is 110V.	
Input current	Primary side rating	•5A/50A/100A/250A/400A (In case using dedicated CT.) (Select with setting mode) •1 to 4000A (Set with setting mode) ※Use a commercial CT with secondary side current of 5A when measure 400A or more. ※Accuracy coverage : 10~100% of rated current of CT	
Special functions	Cut-off current	1.0~50.0%F.S	
	Current threshold for hour meter	1.0~100.0%F.S.	

Accuracy (without error in CT and VT)	Instantaneous electric power (active/reactive/apparent) Integrated electric power (active/reactive/apparent) Voltage Current Electricity charge	$\pm 2.5\%$ F.S. ± 1 digit (at 20°C, rated input, rated frequency, power-factor 1) ※Accuracy coverage: 10~100% of rated current of CT
	Hour meter	$\pm 0.01\% \pm 1$ digit (at 20°C) 〔 In case power on start or current energizing 〕 $\pm 0.01\% + 1s \pm 1$ digit
	Temperature characteristics	$\pm 1.5\%$ F.S. /10°C ± 1 digit (Range of -10 to 50°C based on 20°C for rated input power-factor 1)
	Frequency characteristics	$\pm 1.5\%$ F.S. ± 1 digit (Frequency change $\pm 5\%$ based on rated frequency, for rated input power-factor 1)

8-2-2 Pulse input

Input mode	Addition (Fixed)
Max. counting speed	2kHz /30Hz (Select with setting mode)
Pulse input	Min. input signal width: 0.25ms (When 2kHz selected) /16.7ms (When 30Hz selected) ON:OFF ratio = 1 : 1
Input signal	Contact / No contact (open collector) • Impedance when shorted: 1kΩ • Residual voltage when shorted: Max. 2V • Impedance when open: 100kΩ
Output mode	HOLD (Over count)
Number of Digit	8-digit (0 to 99999999)

8-3 Pulse output (Transistor output) Specifications

Number of output point	1 point
Insulation method	Optical coupler
Output type	Open collector
Output capacity	100mA 30V DC
Pulse width	approx. 100ms
ON state voltage drop	1.5V or less
OFF state leakage current	100 μA or less
Pulse output unit	0.001/0.01/0.1/1/10/100kWh/Alarm(AL-P)/Counter(Cnt) (Selectable with setting mode)

* We recommend the setting of minimum unit for pulse output for measurement shown as below.
Output pulse: 4 pulse or less per 1sec.

How to calculate

(Unit for pulse output: PL-P) > (Max. measurement power [kW]) / (3600[s] × 4 [pulse/s])

- Caution** (1) Improper unit setting may cause miss counting.
(2) If the OFF time is too short, there is a possibility of counting errors.

8-4 Communication Specifications

Interface	Conforming to RS485	
Protocol	MEWTOCOL/MODBUS(RTU) (selectable with setting mode)	
Isolation status	Isolated with the internal circuit	
Number of connected units	99 (max.) ※2 ※3	
Transmission distance	1200m (max.) ※1	
Transmission speed	19200/9600/4800/2400bps (selectable with setting mode)	
Transmission Format	Data length	8bit/7bit (selectable with setting mode) ※4
	Parity	Not available / Odd number / Even number (selectable with setting mode)
	Stop bit	1bit (fixed)
Communication method	Half-duplex	
Synchronous system	Synchronous communication method	
Ending resistance	approx. 120 Ω (built-in)	

◆Factory settings

Protocol	Station no.	Transmission speed (Baud rate)	Data length	Parity	Stop bit
MEWTOCOL	1	19200 bps	8 bit	Odd number	1 bit (fixed)

※1 Please check with the actual devices when some commercial devices with RS485 interface are connected. The number of connected devices, transmission distance, transmission speed may be different according to using transmission line.

※2 For RS485 converter on the computer side, we recommend SI-35 and SI-35USB (from LINE EYE Co.,Ltd.).

※3 When using SI-35,SI-35USB or PLC from Matsushita Electric Works, Ltd. (which can be connected up to 99 units), up to 99 Eco-POWER METER can be connected. In case using this system with the other devices, up to 31 Eco-POWER METER can be connected.

※4 With MODBUS(RTU) protocol, it works only with 8bit.

8-5 Dedicated Current Transformer Specifications

Par no.	AKW4801	AKW4802	AKW4803	AKW4804
Primary side rated current	5A / 50A	100A	250A	400A
Rated secondary side current	1.67mA / 16.7mA	33.3mA	125mA	200mA
Winding (Turn)	3000	3000	2000	2000
Ratio error	±2.0% F.S.			
Hole Dia (mm)	φ 10	φ 16	φ 24	φ 36
Breakdown voltage(initial)	AC1000V/1min (Between through hole and output lead wire)	AC2000V/1min (Between through hole and output lead wire)		
Insulation resistance(initial)	Min. 100MΩ (at DC500V) (Between through hole and output lead wire)			
Vibration resistance	Functional	10~55Hz(1cycle/ minute) single amplitude of 0.375mm (1 hrs. on X,Y and Z axes)		
	Destructive	10~55Hz(1cycle/ minute) single amplitude of 0.15mm (10 min. on X,Y and Z axes)		
Shock resistance	Functional	Min. 98m/s ² (4 times on X,Y and Z axes)		
	Destructive	Min. 294m/s ² (5 times on X,Y and Z axes)		
Output protection level	±7.5V with clamp element	±3.0V with clamp element		
Permissible clamping frequency	Approx. 100 times			
Ambient temperature	-10 to +50°C (without frost and non-condensing)			
Storage temperature	-20 to +60°C (without frost and non-condensing)			
Ambient humidity	35~80%RH (at 20°C non-condensing)			
Weight	Approx. 50g (Trunk cable included)	Approx. 80g (Trunk cable included)	Approx. 200g (without trunk cable)	Approx. 300g (without trunk cable)

Note) Dedicated current transformers (CT), AKW4801, 4802,4803,4804, are dedicated for low voltage under 440V system. They can not be used for high voltage circuit. In case measuring high voltage circuit, make a 2-step construction by combination of a commercial CT of secondary side current 5A for high voltage and the dedicated CT for 5A (AKW4801).

8-6 Self-diagnostic function

If an error occurs, the following indication will be given.

Indicator	Meaning	Output status	To recover
ERR0	CPU error	OFF	Turn the power off and then on again.
ERR1	Memory error*		EEP-ROM life ended. Replace the unit.

*Includes the possibility that the EEPROM's life has expired.

8-7 Power Failure Memory

Eco-POWER METER memories integrated electric power and working status to internal EEPROM until when power supply is off. (Power failure guarantee)

And every time to change each setting, each setting value is memorized to internal EEPROM at the same time. Therefore, change setting frequently makes EEPROM's life short. Avoid to usage like this.

*Especially be careful if you set by communication.

Chapter 9 Mounting

9-1 Dimensions

9-1-1 Main unit

(Unit: mm)
(Clearance: ± 1.0)

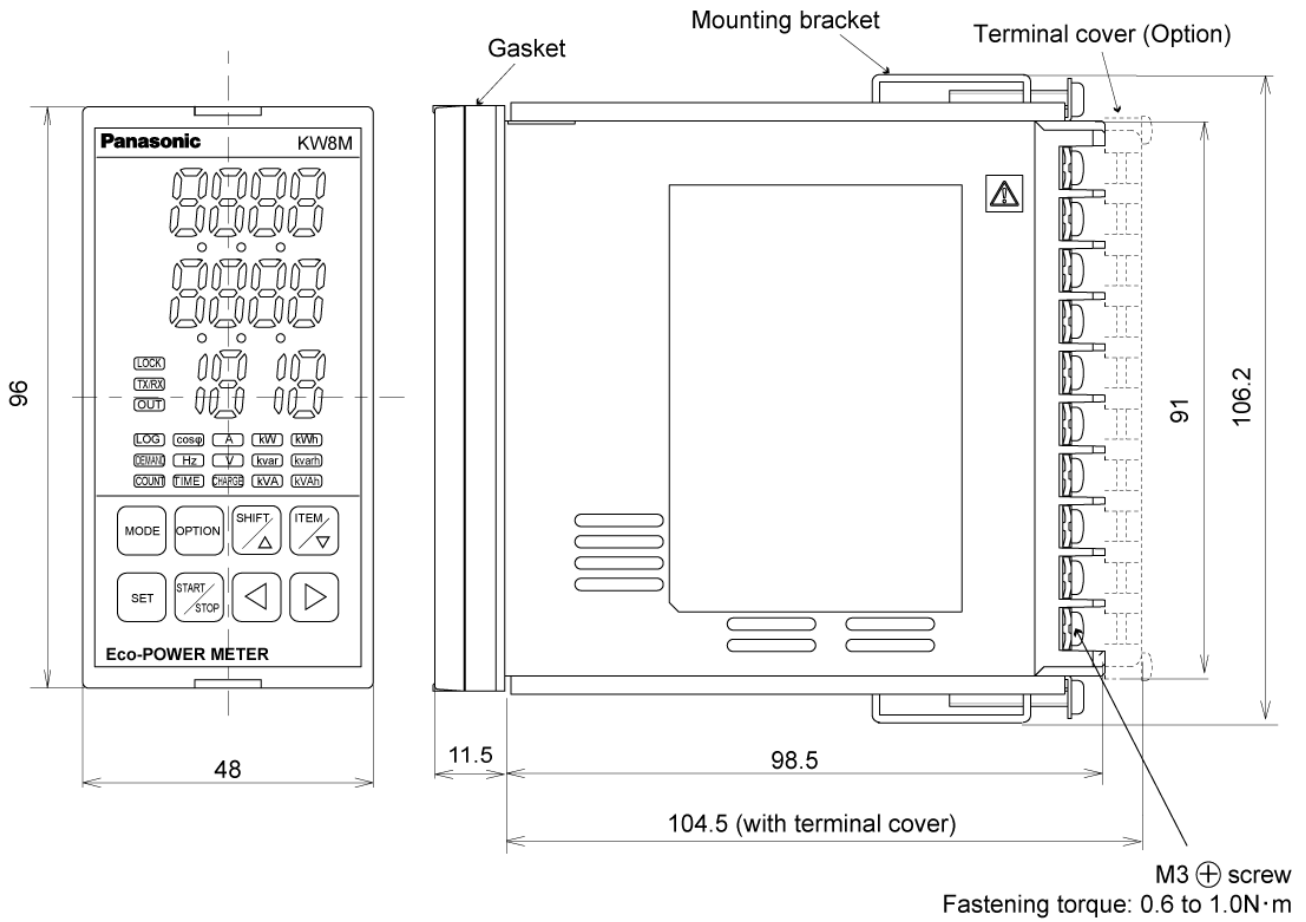

9-1-2 Dedicated CT

◆ For 5A/50A(AKW4801)

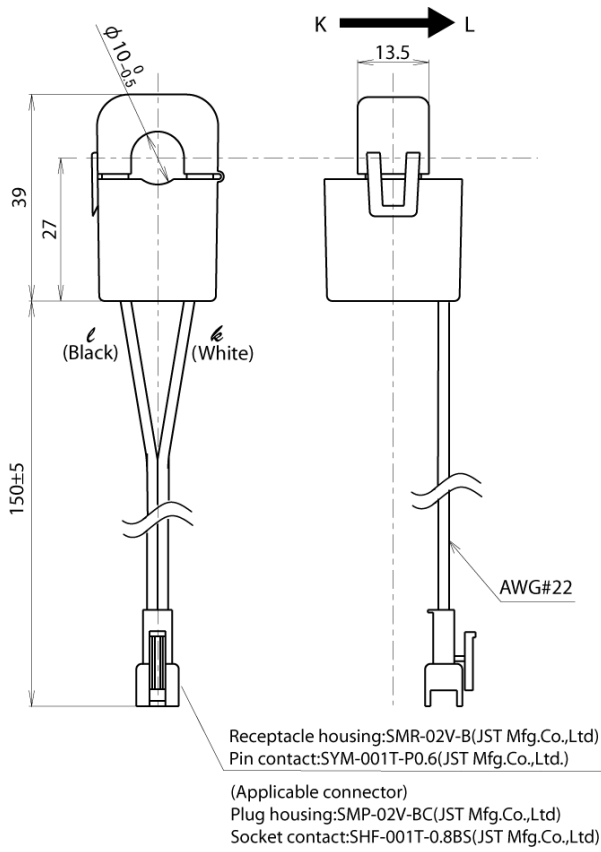

◆ For 100A(AKW4802)

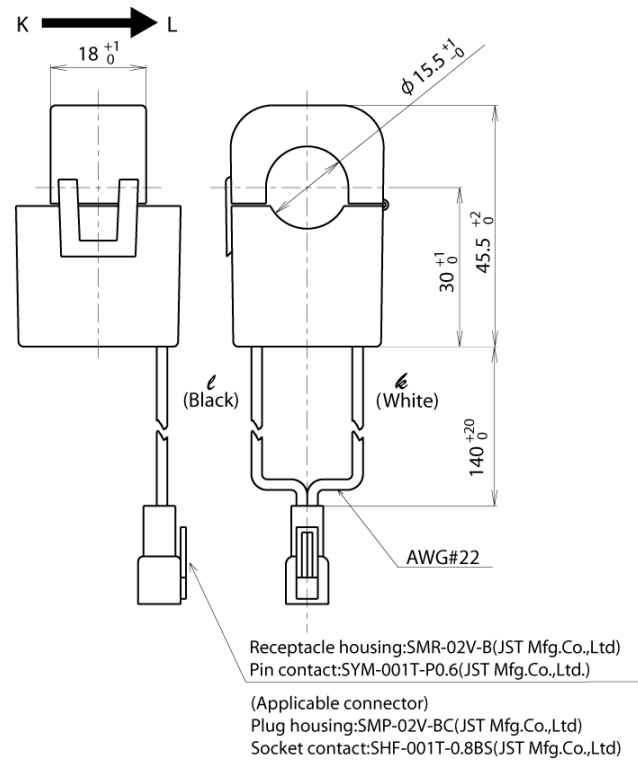

◆ Attached trunk cable: L=(1000)

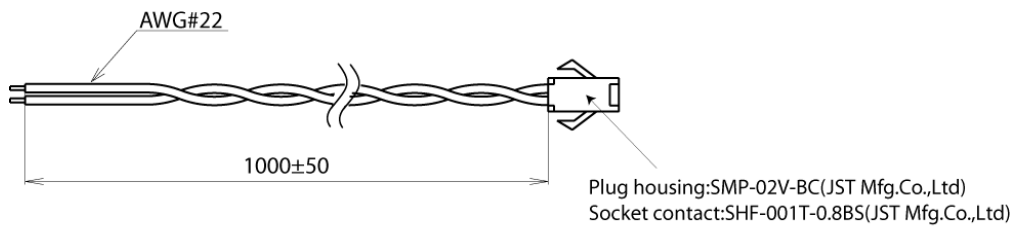

◆ For 250A (AKW4803)

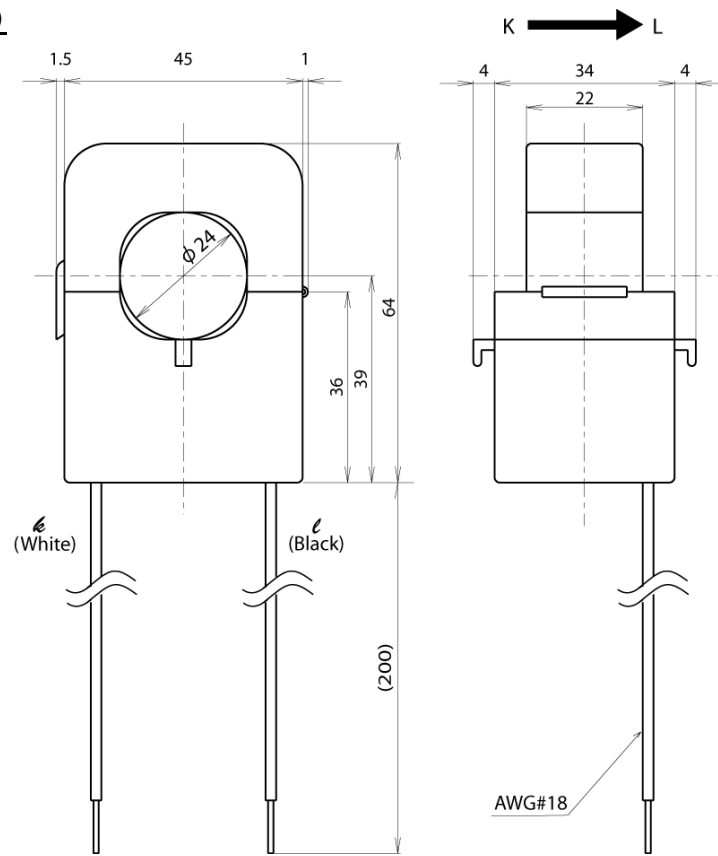

◆ For 400A (AKW4804)

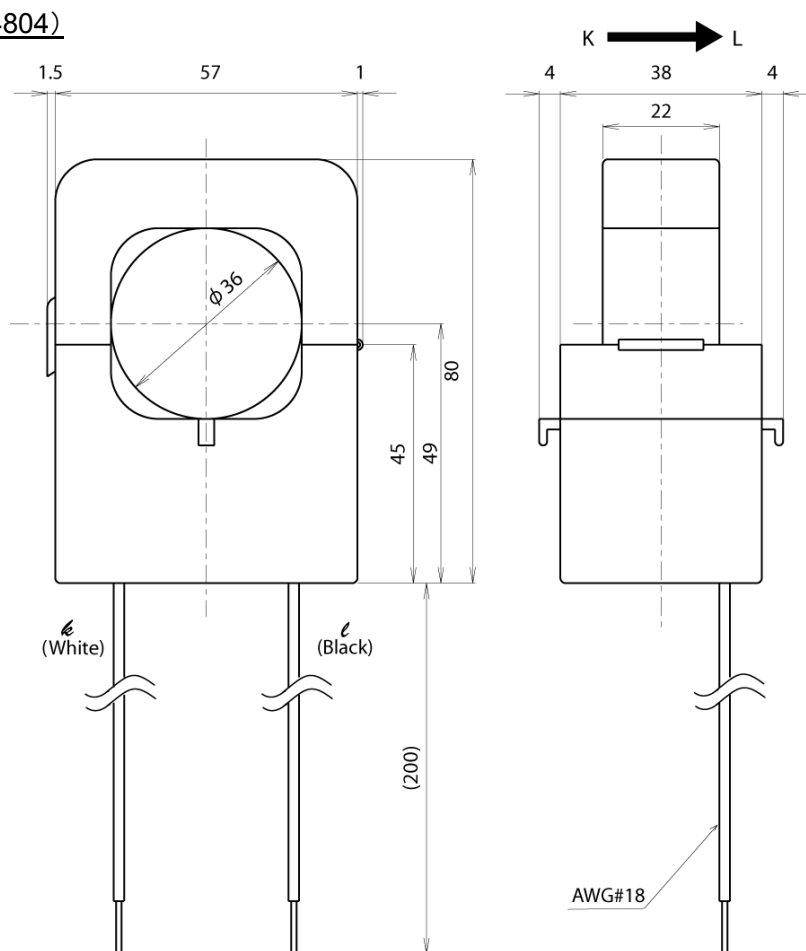

9-2 Panel cutout

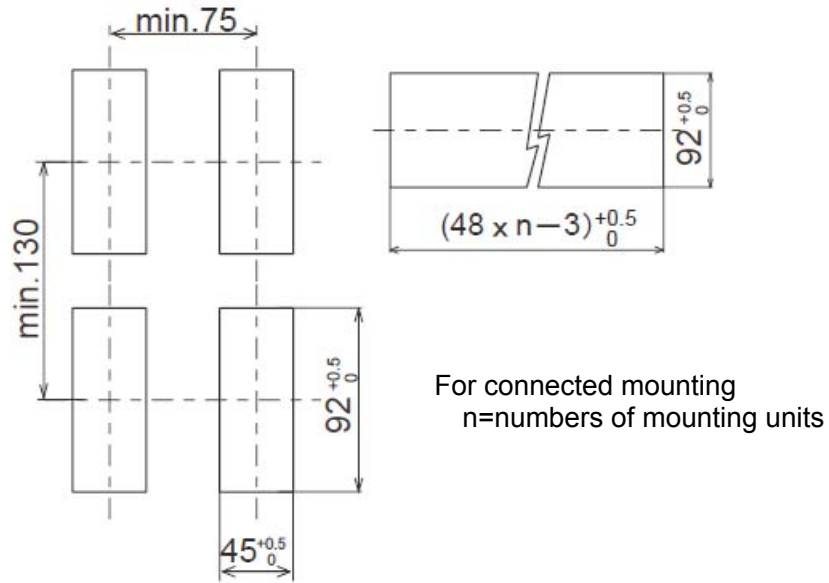

9-3 Panel mounting

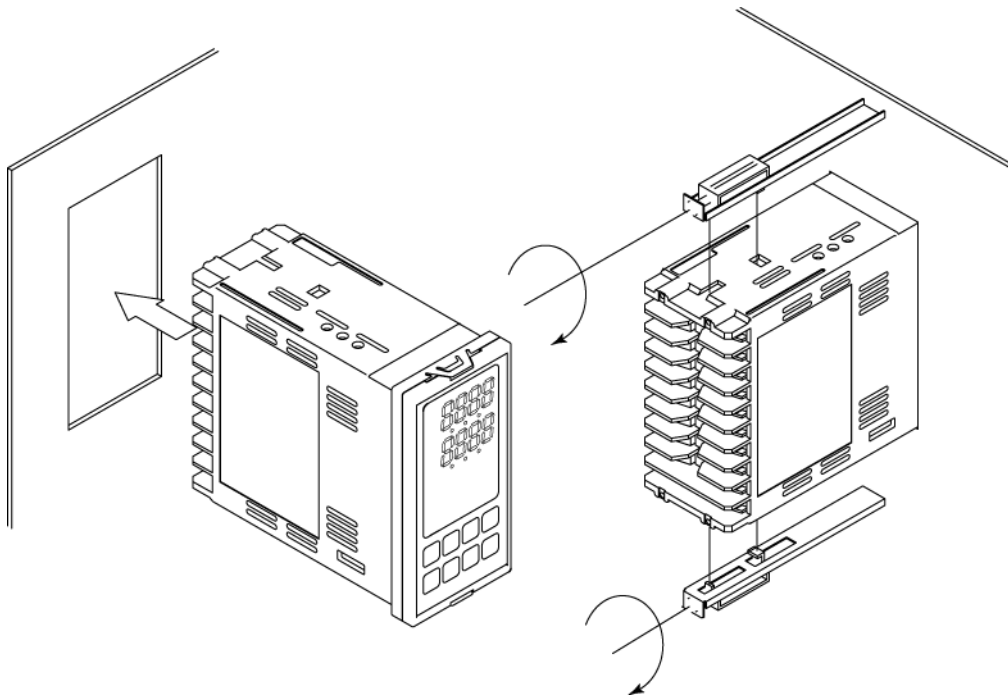

- 1) Insert a unit from the front of the panel.
 - 2) Attach the mounting bracket by the holes at the top and bottom of case and secure in place with screws.
- Fastening torque: approx. 0.12N·m)
 - Panel thickness: 1 to 15mm

These materials are printed on ECF pulp.
These materials are printed with earth-friendly vegetable-based (soybean oil) ink.



Please contact

Matsushita Electric Works, Ltd.

Automation Controls Business Unit

Head Office: 1048, Kadoma, Kadoma-shi, Osaka 571-8686, Japan

Telephone: +81-6-6908-1050

Facsimile: +81-6-6908-5781

<http://www.mew.co.jp/ac/e/>

All Rights Reserved © 2007 COPYRIGHT Matsushita Electric Works, Ltd.

Specifications are subject to change without notice.

Printed in Japan.